

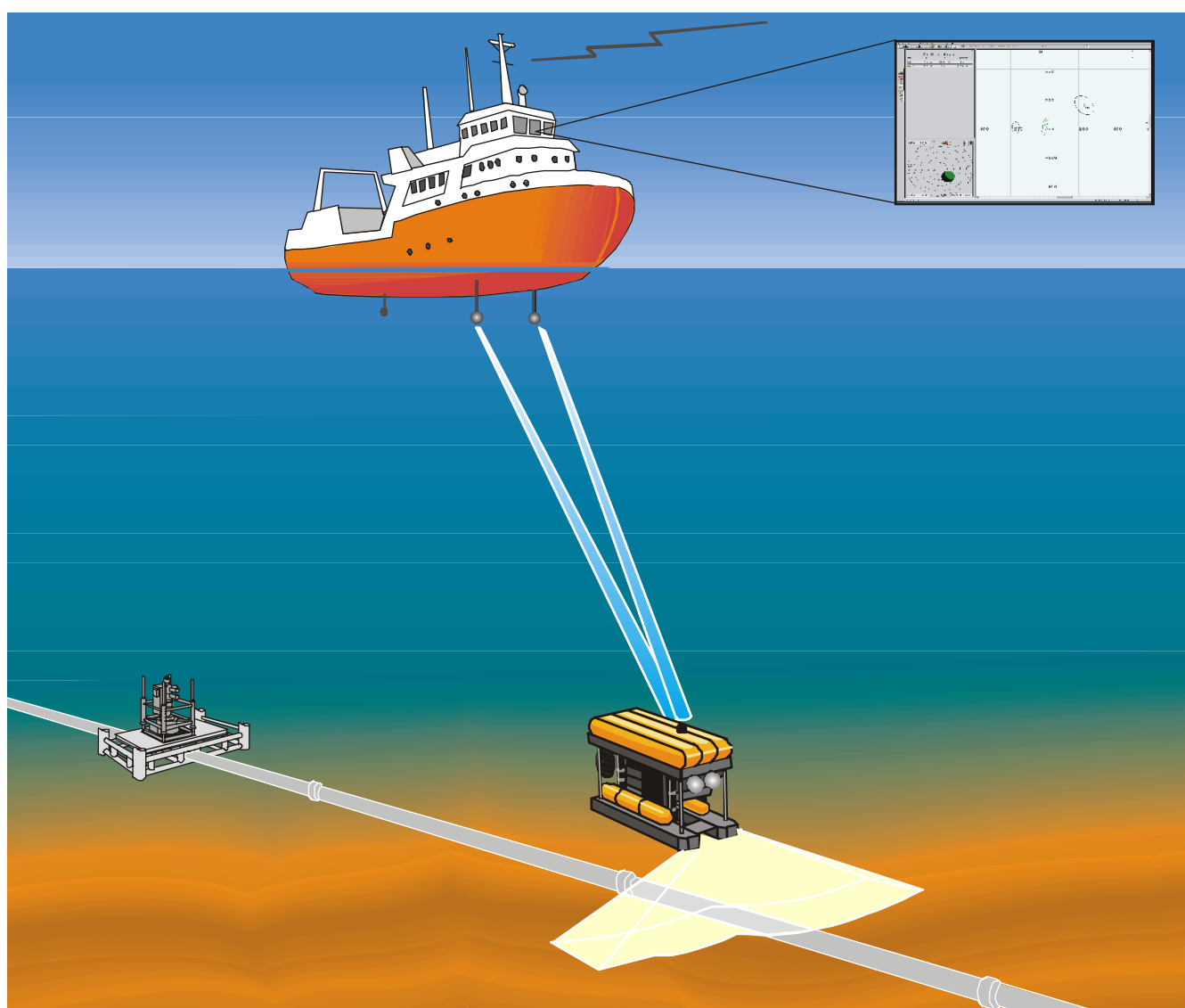

KONGSBERG

Instruction manual

APOS for the HPR 400 series



APOS for the HPR 400 series

Acoustic Positioning Operator Station (APOS)

Instruction manual

Note

Kongsberg Maritime AS makes every effort to ensure that the information contained within this document is correct. However, our equipment is continuously being improved and updated, so we cannot assume liability for any errors which may occur.

Warning

The equipment to which this manual applies must only be used for the purpose for which it was designed. Improper use or maintenance may cause damage to the equipment or injury to personnel. The user must be familiar with the contents of the appropriate manuals before attempting to install, operate or maintain the equipment.

Kongsberg Maritime AS disclaims any responsibility for damage or injury caused by improper installation, use or maintenance of the equipment.

Copyright

© 2003 Kongsberg Maritime AS

The information contained within this document remains the sole property of Kongsberg Maritime AS. No part of this document may be copied or reproduced in any form or by any means, and the information contained within is not to be communicated to a third party, without the prior written consent of Kongsberg Maritime AS.

Contact information

Support: ui@kongsberg.com

Sales: subsea@kongsberg.com

Kongsberg Maritime AS

Strandpromenaden 50
P.O.Box 111
N-3191 Horten,
Norway

Telephone: +47 33 02 38 00
Telefax: +47 33 04 47 53
www.kongsberg.com
E-mail: subsea@kongsberg.com



KONGSBERG

Sections

This is the Instruction manual for the Acoustic Positioning Operator Station (APOS) used with a Hydroacoustic Position Reference (HPR) 400 system. It contains a general description of the HPR400 series systems, protocols, and how to get started on the APOS. The manual includes the following sections:

1 APOS Operator manual

This section includes the standard operator manual for the APOS and includes an introduction to the APOS, abbreviations and terms, how to get started on the APOS, LBL and SBBL principle of operation and operator maintenance.

2 HPR 400 Product description

This section describes the HPR 400 acoustic positioning system. It includes positioning principles, applications, system units, configurations and functions. It also includes technical specifications and drawings.

3 Attitude formats description

This section describes the gyro and VRS formats that the HiPAP and HPR system can receive.

4 HPR 400 Binary Communication Protocol

This section describes the HPR 400 standard telegrams sent to external equipment.

5 HPR 300 telegrams

This section describes the HPR 300 external equipment telegram formats.

6 Transponder Quick Reference Guide

This section includes the Transponder Quick Reference Guide, and references to the available transponder Instruction Manuals.

Remarks

References

Further information about how to operate the Kongsberg Acoustic Positioning Operator Station (APOS) is found in:

- APOS on-line help system

Further information about the Kongsberg Acoustic Positioning systems using APOS software, are found in the following manuals

HPR 400 Series system	Hull units
HPR 400 series Installation manual	HL 3880 Hull Unit Instruction manual
HPR 400 series Maintenance manual	HL 3880 Ex-1 Hull Unit Instruction manual
	HL 3880 TR Hull Unit Instruction manual
	Swaco Hydraulic Hull Unit Instruction manual

The reader

This manual assumes the operator has some knowledge of the general principles of operation, the standard display modes and terminology used in acoustic positioning systems.

References

(The information on this page is intended for internal use)

Documents

Sect	Title	Archive	Reg. no.	Rev.
0	Cover and contents	AA000	857-160925	E
1	Acoustic Positioning Operator Station (APOS) Operator manual	AA000	850-160841	D
2	HPR 400 Product description	AA000	855-201391	E
3	Attitude formats description	AA000	853-201392	C
4	HPR 400 Binary Communication Protocol	AA000	857-160898	B
5	HPR 300 telegrams	AA000	849-108368	B
6	Transponder Quick Reference Guid	AA000	859-164414	B

(* The latest versions of all document modules are included as standard.)

Document logistics

Rev	Date	Written	Checked	Approved
A	01.06.98	GM	JEF	JEF
B	01.07.99	GM	JEF	JEF
C	10.10.01	GM	THG	JEF
D	14.12.01	GM	THG	JEF
E	02.10.02	GM	EB	RBr
F				

(The original signatures are recorded in the company's logistic database.)

Rev	Comments
A	Original issue.
B	Implemented the HPR 300 telegrams section. Minor corrections in the text
C	Implemented the Transponder Quick Reference Guide. New layout. Ref. EM 857-160925C.
D	Document changed to include only HPR 400 serie. Ref EM 857-160925D
E	Updated company information. Implemented HPR 400 Product description. Removed the NMEA information. Ref EM 857-160925E

To assist us in making improvements to the product and to this manual, we would welcome comments and constructive criticism. Please send all such - in writing or by e-mail - to:



Simrad AS
Documentation Department
P.O.Box 111
N-3191 Horten
Norway
or e-mail:

simrad.documentation@simrad.com

850-160841

Acoustic Positioning Operator Station (APOS)

This document is the Operator manual for the Acoustic Positioning Operator Station (APOS) for use with the High Precision Acoustic Positioning (HiPAP) and Hydroacoustic Position Reference (HPR) 400 series of systems.

Document revisions

Rev	Date	Written by	Checked by	Approved by
A	01.06.98	GM	JEF	JEF
B	22.02.99	GM	JEF	JEF
C	08.10.99	GM	HPJ	JEF
D	02.10.03	GM	HPJ	JEF

(The original signatures are recorded in the company's logistic database)

Document history

- Rev. A** First edition.
- Rev. B** Updated to implement minor corrections. Refer to EM 160841B.
- Rev. C** Updated to implement minor corrections in the text. Refer to EM 160841C.
- Rev. D** Implemented Windows XP. Removed the APOS on-line help example. New keyboard and trackball. Minor corrections in the text. Refer to EM 850-160841D.

Contents

INTRODUCTION.....	5
Manual content.....	5
General description.....	5
ABBREVIATIONS TERMS AND DEFINITIONS	6
Introduction.....	6
Abbreviations.....	6
General terms.....	6
Windows terminology.....	7
General.....	7
Screen.....	9
Cursor operation.....	10
GETTING STARTED.....	11
General.....	11
User levels.....	11
Keyboard.....	11
Start and stop.....	12
Start up procedure.....	12
Stop procedure.....	13
To lower and rise the transducer(s).....	14
Using the remote control.....	14
Using the hoist control.....	14
APOS on-line help system.....	15
OPERATOR MAINTENANCE	16
Maintenance philosophy.....	16
Preventive maintenance.....	16
Cable terminals.....	16
Operator station.....	16
LBL PRINCIPLES OF OPERATION.....	17
Introduction.....	17
Definitions.....	17

Mathematical terms.....	17
LBL terms.....	18
HiPAP / HPR terms	19
LBL measurement principles	20
Positioning	20
Calibration.....	21
Combined use of LBL and SSBL	22
Geographical calibration.....	22
Super array and Tp array	24
Geographical coordinates	26
Quality control of the data	27
Local calibration.....	27
Geographical calibration.....	27
Positioning	28
Transponder Modes	28
Operation.....	29
Measure ranges	29
Execute the local calibration	29
Position a vessel or ROV	29
Position a transponder	30
Geographical calibration.....	30
SSBL PRINCIPLES OF OPERATION	31
Introduction.....	31

INTRODUCTION

Manual content

This Operator manual provides a general introduction to the APOS, and how to get started. Operator maintenance, Long Base Line (LBL) and Super-Short Base Line (SSBL) principles of operation are also included.

General description

The HiPAP and HPR 400 Series of systems are both controlled and operated by use of the APOS software. The APOS runs on the APC 10 as a stand alone system, or on the Common Operator Station (COS) 100 unit in an integrated Dynamic Positioning (DP) and HiPAP / HPR 400 system.

Examples of HiPAP / HPR configurations are shown in section 2, Product description.

The APOS software includes the following main functions:

- Integrates several HiPAP / HPR 400 transceivers
- Integrates DP and HiPAP / HPR 400 system
- User interface
- Interfacing HiPAP / HPR 400 transceivers
- Ray bending compensation
- Long Base Line calculations
- The SSBL calculations are done in the transceiver
- Interfaces DP and survey computer
- On-line help

The APOS software runs on a Windows XP platform. It uses standard Windows graphical user interface.

ABBREVIATIONS TERMS AND DEFINITIONS

Introduction

This chapter includes abbreviations used in this manual, general terms used within the APOS, and basic Windows terminology.

Abbreviations

APC	Acoustic Positioning Computer
APOS	Acoustic Positioning Operator Station
COS	Common Operator Station
DGPS	Differential GPS
DP	Dynamic Positioning
GPS	Geographical Positioning System
HiPAP	High Precision Acoustic Positioning
HPR	Hydroacoustic Position Reference
LBL	Long Base Line
OS	Operator Station
ROV	Remotely Operated Vehicle
SDP	Simrad Dynamic Positioning
SSBL	Super-Short Base Line
TD	TransDucer
TP	TransPonder
UTM	Universal Transverse Mercator
VRS	Vertical Reference System

General terms

The general terms are described in alphabetically order.

Bearing

The horizontal direction of one terrestrial point from another, expressed as the angular distance from a reference direction, clockwise through 360°.

Cartesian coordinate system

A coordinate system (local system) where the axes are mutually-perpendicular straight lines.

Clump weight

An anchor line element connected at a fixed position on an anchor line, causing a concentrated vertical force downwards on the anchor line.

Course

The horizontal direction in which a vessel is steered or is intended to be steered, expressed as angular distance from north, usually from 000° at north, clockwise through 360°. Strictly, this term applies to direction through the water, not the direction intended to be made good over the ground. Differs from **heading**.

Datum

Mathematical description of the shape of the earth (represented by flattening and semi-major axis).

Geodetic coordinate system

A mathematical way of dealing with the shape, size and area of the earth or large portions of it. Normally UTM coordinates with reference to a datum.

Heading

The horizontal direction in which a vessel actually points or heads at any instant, expressed in angular units from a reference direction, usually from 000° at the reference direction clockwise through 360°. Differs from **course**.

Windows terminology**General**

Windows are the basic objects of the Microsoft Windows operation system. They will always be displayed with the same layout and functionality, as long as the system programmer did not change the configuration.

Note !

The APOS on-line help includes an illustration of a general window, and the including general properties.

The following paragraphs present a short description of the most used general properties in alphabetical order.

Check box

A small square box  that appears in a dialogue box and that can be turned on and off. A check box contains a tick mark when it is selected and is blank when it is not selected.

Choose

To perform an action that carries out a command in a menu or dialogue box. *See also* **Select**.

Command

A word or phrase, usually found in a menu, that you choose in order to carry out an action.

Command button

A rectangle with a label inside that describes an action, such as OK, Apply or Cancel. When chosen, the command button carries out the action.

Cursor

The pointer symbol that is displayed on the screen and that can be moved with the trackball.

Dialogue/Dialog box

A box that appears when the system needs additional information before it can carry out a command or action. *See also* **Check box**, **Command button**, **List box**, **Option button** and **Text box**.

Greyed

Describes a command or option that is listed in a menu or dialogue box but that cannot be chosen or selected. The command or option appears in grey type.

List box

A box within a dialogue box containing a list of items. If the list of available items is longer than the displayed list box, the list box will have a vertical scroll bar that lets you scroll through the list. A list box may be closed when you first see it. Selecting the down arrow next to the first item in the list will display the rest of the list.

Menu

A group listing of commands. Menu names appear in the menu bar beneath the caption bar. You use a command from a menu by selecting the menu and then choosing the command.

Option button group

A group of related options in a dialogue box. Only one button in a group can be selected at any one time.

Point

To move the cursor on the screen so that it points to the item you want to select or choose.

Radio button

A small round button is appearing in a dialogue box  (also known as a “Option” button). You select a radio button to set the option, but within a group of related radio buttons, you can only select one. An option button contains a black dot when it is selected and is blank when it is not selected.

Select

To point and click at the item that the next command you choose will affect. *See also Choose.*

Slider

Used to setting parameter values between a minimum and a maximum value. Drag the slider in the required direction.

Status bar

Displays general useful information.

Text box

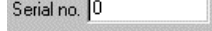
A box within a dialogue box  in which you type information needed to carry out a command. The text box may be blank when the dialogue box appears, or it may contain text if there is a default option or if you have selected something applicable to that command. Some text boxes are attached to a list box, in which case you can either type in the information or select it from the list.

Title bar

Displays an application-defined line of text. The title bar also used to move/drag the window.

Toolbar

A collection of buttons to give a fast entry to the most used commands.

Screen

The screen presentations are described in detail in the APOS on-line help.

Menus

Main menus are items in the menu bar. They may contain:

Sub menus:	marked by ►
Dialogue windows:	marked by ...
Commands:	unmarked

Cursor operation

The trackball is used to positioning the cursor on the screen. The most common operations are:

Function	Definition	Common use
Click	To press and release a button, without moving the cursor. If no trackball button is specified, the left button is assumed.	Select the cursor insert point, activate an operation, activate / inactivate windows or controls.
Drag	To press and hold down a button while moving the trackball.	Move items. For example, you can move a dialogue box to another location on the screen by dragging its title bar. Press and hold the button down while moving the trackball.
Point	Move the cursor to the wanted screen location.	Prepare for selection /operation.

GETTING STARTED

General

This chapter describes the basic operation, how to switch the APOS on and off, and how to lower and raise the transducer(s).

The “getting started” description is based on an already installed APOS software.

Note !

For more information refer to the APOS on-line help system.

User levels

The APOS is - regarding functional possibilities and operation, configured in the following two user levels:

Operator: This level is used for the daily normal operation.

Service: This level requires password, and is for service personnel only.

Keyboard

The keyboard is a PS/2 keyboard. It has US layout and includes back-lighting. The keyboard can be mounted on the APC 10 or be placed on a desktop.



(Cdr7079a)

Trackball

The trackball is designed for easy use.



Use of trackball

The trackball is used to position the cursor on the screen. Each movement of the trackball moves the cursor.

- The left button is used to click on buttons, operate menus and select displayed symbols.
- The right button is used to display menus and pop-up windows.

The most common trackball operations are; pointing, clicking and dragging.

Start and stop

Start up procedure

The following procedure describes how to start the APOS from *Power Off* position. (Normally the system is kept on 24 hours a day.)

1. Switch on the power. (The power On / Off switch is normally located at the front of the cabinet.) The APOS is ready for use after approximately 1 minute.
2. Switch on the monitor. (The power On / Off switch is normally located at the lower front part of the monitor.)
 - First the desktop menu appears, and after some time the APOS main window appears.
3. If required, adjust contrast and brightness in order to obtain required display settings. (The buttons are located at the lower front part of the monitor.)
4. Ensure that you are in control of the system by pressing the  button. When in control, the button becomes disabled. (If the system is already in control, do not click the button).

Note !

If there are more than one operator station in the system, the button will automatically become enabled again if another operator station takes control.

Note ! *Ensure that the configuration of the transponders available in your system is performed. How to configure the transponders, see the APOS on-line help.*

Caution ! *Remember to lower the transducer(s)! Refer to page 12.*

You are now ready for operation!

Note ! *How to operate the APOS, see page 15 and the APOS on-line help system.*

Stop procedure

Normally the system is kept on 24 hours a day. If a controlled shutdown is required, it is important to proceed as follows:

- 1. Select **File -> Stop/Shutdown**

The following windows is displayed.

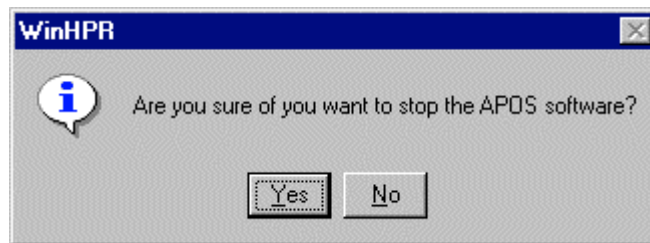

2. Select **Yes**.
3. The APOS software will shut down, and you will return to the desktop.

To lower and rise the transducer(s)

Note ! *The HiPAP / HPR may be a part of a larger system. Switching on the larger system will then normally power up the HPR system as well, and only lowering of the transducer will be required.*

Using the remote control

1. To lower the transducer, press the **DOWN** button on the Remote Control Unit. Observe that the **IN** and **STOP** lamps extinguish. When the transducer is fully lowered, the yellow **OUT** lamp will be lit.
2. To rise the transducer, press the **UP** button on the Remote Control Unit. Observe that the **IN** and **STOP** lamps extinguish. When the transducer is fully risen, the yellow **IN** lamp will be lit.

Note ! *The red STOP button on the Remote Control Unit may be used to stop the transducer hoisting and lowering operations at any position. When this button is pressed, the yellow STOP lamp will light. The hoisting or lowering operations are continued from the stop position by pressing the UP or DOWN buttons.*

Using the hoist control

1. To lower the transducer, open the Hoist Control Unit door and set rotary switch **S1** to **LOWER**. Once the Hull Unit has reached the required position, (will stop automatically) set the switch **S1** to **STOP**.
2. To rise the transducer, open the Hoist Control Unit door and set rotary switch **S1** to **HOIST**. Once the Hull Unit has reached the required position, (will stop automatically) set the switch **S1** to **STOP**.

Note ! *The red STOP button on the remote control unit may be used to stop the transducer hoisting and lowering operations at any position. When this button is pressed, the yellow STOP lamp will light. The hoisting or lowering operations are continued from the stop position by pressing the UP or DOWN buttons.*

APOS on-line help system

When operating the APOS, the on-line help is available by activating the APOS Help menu button, or the F1 button on the WinKeyboard.

The on-line help may also be activated from a dialogue box, provided that the help button is available in that particular dialogue box.

The on-line help menu includes the following selections:

- **Help**
General help
- **About APOS**
Includes the APOS version

OPERATOR MAINTENANCE

Maintenance philosophy

For the APOS, corrective maintenance is normally performed by replacing modules and circuit boards. This type of maintenance must be carried out by a qualified maintenance engineer.

Further information about maintenance of the Acoustic Positioning systems are found in the following manuals:

- HiPAP Instruction manual
- HPR 400 Series Maintenance manual.

Preventive maintenance however, may be performed by the system operator.

Preventive maintenance

Caution !

Do not use strong liquid detergent when cleaning the units. This may be fatal to the surface.

Cable terminals

All cables should be checked and tightened at least once every three months. This will prevent the screws from loosening resulting in poor contact for the cables.

Operator station

Clean the operator station and display exterior with a damp cloth to remove dirt, dust, grease etc.

The keyboard should be cleaned carefully with a damp cloth.

LBL PRINCIPLES OF OPERATION

Introduction

This chapter describes the theory of operation of the LBL. The terms used in LBL positioning are defined, and the mathematical principles are described.

Definitions

Mathematical terms

Standard deviation tells how much a variable varies around its mean value. It is often written as σ . If the variable is normally distributed, 68% of its values are expected to be between (Mean_value - σ) and (mean_value + σ).

Variance is the square of the standard deviation, i.e. σ^2 .

Root Mean Square (RMS) of a set of values is a mean of the values in which the greater values contribute more than the smaller values. It is often used instead of the mean value.

Iteration is a repetitive mathematical process. Some algorithms need starting values for some of the variables before they may be executed. The result of the calculation is a new set of values for those variables that are closer to the answer than the old ones. By repeating the algorithm starting at the new values, the result becomes more accurate each time. Each execution is called an iteration, and the algorithm is termed iterative.

Cartesian coordinates are measured in a coordinate system with three mutually perpendicular axes. In this text, the axes are named EAST, NORTH and DEPTH. NORTH is normally the geographical north direction, and EAST the geographical East direction. You are allowed to select other directions, but you must be consistent. The origin of the coordinate system has the coordinates (0,0,0).

Polar coordinates. The polar coordinates of a point are:

- **Range** - The horizontal distance from the origin to the point.
- **Bearing** - The horizontal direction from the origin to the point. 0 is the north direction. The bearing increases clockwise to 360°.
- **Depth** - The vertical distance from the origin to the point.

LBL terms

TP Array. LBL positioning is based on range measurements to the transponders on the seabed. These transponders are called a “transponder array”.

Local calibration. The LBL positioning algorithms must know the coordinates of the transponders in the transponder array relative to a local origin. The process to decide these coordinates is called the local calibration of the transponder array. It is performed by first measuring the ranges between the transponders in the array and then calculating their coordinates based on the ranges.

Geographical calibration. Decides the location of the local origin in latitude and longitude, and the rotation of the local north axis relative to geographical north.

Range residual. HiPAP / HPR measures ranges to decide the position of a transponder or a transducer. Normally, more ranges than necessary are measured. Then the position is calculated based on a best fit of the measured ranges. The residual of a range is the measured range minus the range calculated by using Pythagoras' theorem on the calculated positions.

Local coordinates. The origin of the local coordinate system is in the area covered by the transponder array. The axes are called EAST, NORTH and DEPTH. The NORTH axis is not necessarily pointing in the geographical north direction. The names of the axes in the coordinate system are written in upper case letters (EAST, NORTH), and the geographical directions are written in lower case letters.

Geographical coordinates. When a geographical calibration is performed, positions may be presented in geographical coordinates; either in latitude and longitude or in UTM coordinates.

Initial positions. The positions of the transponders in the transponder array inserted before the local calibration is performed. The positions are given in local or geographical coordinates. The only requirement to the accuracy of these positions is that they roughly indicate the transponder positions relative to each other.

Calibrated positions. The positions of the transponders in the transponder array calculated in the local calibration. The positions are given in local coordinates.

Error ellipse. There is an uncertainty associated with all positions, both initial and calibrated. This uncertainty is expressed as a 1-sigma error ellipse both in the input to and the output from the HiPAP / HPR system. The error ellipse has a major and a minor semi-axis, and the direction of the major semi-axis relative to north is specified. Assuming that the uncertainty of the position is normally distributed, the probability that the position really is within the error ellipse is $0.67 \times 0.67 = 45\%$.

HiPAP / HPR terms

The APOS is the HiPAP / HPR System Controller. It consists of a Pentium based PC. It can also contain a keyboard and circuit boards for serial lines, Ethernet etc. as options.

HPR 400 is a transceiver. It consists of single Europe circuit boards normally mounted in a 19" rack. The PCBs may be mounted in a cylinder for subsea use. The transceiver measures ranges and SSBL directions and handles telemetry.

HiPAP is a transceiver with one spherical transducer.

A Transducer consists of elements (vibrators) and some electronics. It converts the electrical transmission signals generated by the transceiver into hydroacoustic pulses. It also converts the hydroacoustic pulses received into electrical signals for the transceiver.

The transducer may be of the ordinary LBL type or of the SSBL type. Both are capable of measuring ranges. The SSBL transducer can also measure directions.

The HPR 4xx consists of an Operator unit, transceiver(s) and transducer(s). There may be up to four transceivers connected to the Operator Unit, and there may be two LBL transducers plus two SSBL or LBL transducers connected to each transceiver. HPR 410 is an SSBL system, HPR 408 is an LBL system while HPR 418 is a combined LBL and SSBL system.

A Transponder consists of a LBL type transducer, electronics and batteries. It is placed on the seabed or on an ROV. The transponders may be commanded by telemetry to execute functions.

Most LBL transponders contain a pressure and a temperature sensor. These are used to decide the transponder depth.

When enabled for positioning, the transponder may be interrogated by two pulses on different frequencies and will then reply with a pulse on a third frequency. The HiPAP / HPR system may command it to switch frequencies.

Each transponder is uniquely identified by a serial number.

LBL measurement principles

LBL positioning is based on range measurements, both for the calibration and for the positioning. The principle is basically the same for positioning and for calibration, but the explanation is split into separate paragraphs in this text.

Positioning

The HiPAP / HPR system measures ranges from a transducer to the transponders on the seabed. A common interrogation channel is used for all the transponders in the transponder array. The HiPAP / HPR system knows the transponder positions. Each range measurement indicates that the transducer is on a sphere with its centre at the transponder and with its radius equal to the range. If more than one range measurement is made, the transducer's position must be on the lines where the spheres intersect.

When the measurements are done on a SSBL type of transducer, the directions may be used together with the range in the calculations. In shallow water, and when an accurate HiPAP transducer is used, the measured directions contribute to a more accurate position.

The depth of the transducer is often known. In these cases, each range measurement indicates that the transducer is on the circle where the sphere around the transponder intersects with the horizontal plane at the transducer. This is illustrated in Figure 1. Here three circles are drawn where the transducer's depth plane crosses the three spheres.

Normally there will be noise on each measurement. That is illustrated on the figure by not letting the three circles intersect exactly in one point. There are three intersections close to each other, and the position can be assumed to be somewhere in the triangle formed by the intersections.

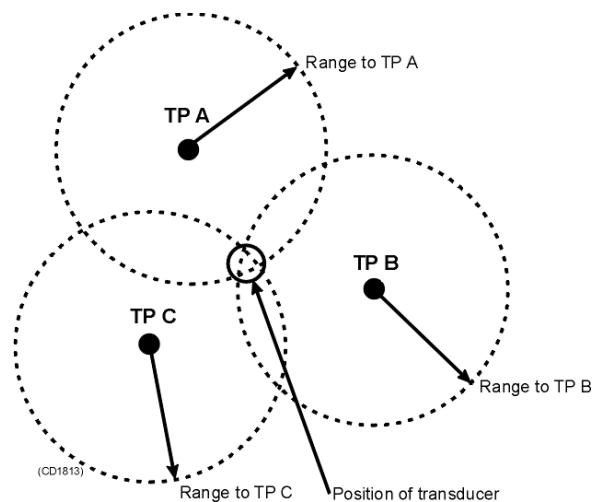

Figure 1 LBL positioning

Normally, more ranges than necessary are measured, and the number of intersections close to each other increases. Still the best guess of the position is somewhere in the space between these intersections. The program uses a weighted least square error algorithm to decide the position. The algorithm is iterative, and the errors are the differences between the measured ranges and the corresponding ranges calculated by using Pythagoras' theorem on the vessel position. These errors are called range residuals.

The iterations start at the vessel's previous known position, and continue until the increment from the previous iteration is less than a preset number of centimetres. The accuracy of the old position does not influence the accuracy of the new position.

Situations may arise when too few ranges are measured. Then there are two possible solutions for the new position. The programs will iterate towards the position closest to the old one.

In standard LBL, the replies from the transponders in the TP array are received on the same transducer as doing the interrogation of the array. In the APOS you can request the replies to be received on other transducers too. The extra measurements make the LBL system more accurate and robust.

Calibration

The "position" used during the calibration consists of the position of each array transponder. Consequently, it contains many coordinate values.

The programs must know something about the transponder positions before the calibration calculations can start. These positions are called "Initial positions". That information must be inserted by you, or it may be read from an ASCII file. SSBL measurements may be used to identify the initial transponder positions.

You must inform the system of the accuracy of the initial positions. This is achieved by specifying a 1-sigma error ellipse for the horizontal position and a standard deviation for the depth. The transponders are often at approximately the same depth, and the range measurements then contain no information about their relative depths. In this case, the depth standard deviation should be set to 0.00 m for all the transponders.

The next step of the calibration is to measure the subsea ranges between the transponders. The range from one transponder to another is normally measured many times. The mean value and the standard deviation of these ranges are then calculated and used later in the calculations.

The programs use a weighted least square error algorithm to decide the positions of the transponders. The algorithm is iterative, starting at the initial positions of the transponders. There are two types of errors as seen from the algorithm.

The **range errors** are the differences between the measured ranges and the corresponding ranges calculated by using the Pythagoras formula on the transponder positions. These errors are called **range residuals**. In the algorithm the squares of the range residuals are weighted with the inverse of the variance calculated during the range measurements. In this way the ranges measured with a small standard deviation have a greater impact on the resulting transponder positions than the ranges measured with a large standard deviation.

The **position errors** are the differences between the calculated transponder positions and the starting values of those positions. In the algorithm, the squares of these errors are weighted with the inverse of the squares of their uncertainties. The uncertainty of a transponder position starts at the error ellipse for the initial position. The uncertainty reduces in size during the calculation, and the result is the uncertainty of the calibrated transponder position.

Combined use of LBL and SSBL

When a transponder array is active on an SSBL transducer, the HiPAP / HPR system may perform SSBL measurements when receiving the replies. The direction information is then used together with the range information to make the system more accurate and robust. The transponders in the transponder array are still classified as LBL transponders.

Transponders may be interrogated as SSBL transponders. They are interrogated using their individual frequencies, and the SSBL measurements are performed as on a pure SSBL system.

The same transponder may not be interrogated as an SSBL transponder and an LBL transponder simultaneously.

When both a transponder array and one or more SSBL transponders are active, the system will alternate between LBL interrogations and SSBL interrogations. The sequence is controlled by the interrogation rate parameters for the LBL and SSBL interrogations.

The transponders used as SSBL transponders are of the same physical type as the LBL transponders. They are, however, commanded to be interrogated on their individual channels and not on the LBL common interrogation channel.

Geographical calibration

Many LBL applications do not perform geographical calibrations. For those applications, you may ignore this chapter.

The relative positions of seabed transponders in TP arrays are calculated based on range measurements between the transponders. When finished, the transponder positions relative to an origin are calculated. This process is called the local calibration.

Normally the position of the origin, and the rotation of the local North axis relative to the geographical north axis, remain unknown after the local calibration. These unknowns are decided in the geographical calibration.

The APOS uses positions of the vessel, simultaneously received from a DGPS system and calculated by the LBL system, as basis for the geographical calibration. DGPS and LBL position pairs are logged at many positions in the area before the calculation is performed. The calculation decides the origin latitude and longitude, and the rotation of the local north axis relative to geographical north axis, using a least square error algorithm.

When the latitude, longitude and rotation of the local origin are calculated, the LBL positions logged are converted to geographical coordinates. There is normally a difference between the LBL geographical position and the DGPS position logged in the same place. This is called the distance residual of the position pair. The residual is the statistical sum of the DGPS error and the LBL error. When these systems work correctly, the sound velocity profile used is accurate, and the local calibration was performed accurately, these residuals are normally in the 1 m order of magnitude.

The most accurate results for the origin position calculations are given if the position pairs are logged evenly distributed around the area. If for example the sound velocity profile is inaccurate, the distance residuals of the position pairs logged in the outer parts of the array may be much larger than the error in the origin calculated. If, on the other hand, position pairs are logged in only one part of the array, the situation could be the opposite - with small residuals but an inaccurate calculation of the origin. It must always be remembered that the objective of the calibration is to establish accurate positions, not to obtain small residuals.

The three parameters calculated in the geographical calibration are the latitude, longitude and rotation. When performing LBL positioning in the area later, errors in latitude and longitude will always contribute to errors in the LBL geographical position. The error in the rotation contributes an error proportional to the distance from the centre of the area in which the position pairs were logged.

The origin calculated is valid for the locations in the transponder arrays used in the LBL positioning during the geographical calibration.

Super array and Tp array

A limit of eight transponders can be in use simultaneously when performing LBL positioning or range measurements for local calibration. The limit is due to the use of frequencies within the frequency band available. The transponders in use simultaneously are named a TP array. The APOS can handle many TP arrays, but only one can be active at any one time.

In many applications, as for example pipe laying and inspection, there is a need to use more than 8 transponders. The places on the seabed where the transponders are placed are called locations.

When all the locations are grouped together, the resulting array is often called the “superarray”.

Each location is a physical transponder. The same physical transponder may be used in more than one TP array, meaning that the TP arrays can overlap.

Example: Location 8 and 9 are used in both TP array 1 and TP array 2 because the arrays overlap, as shown in below.

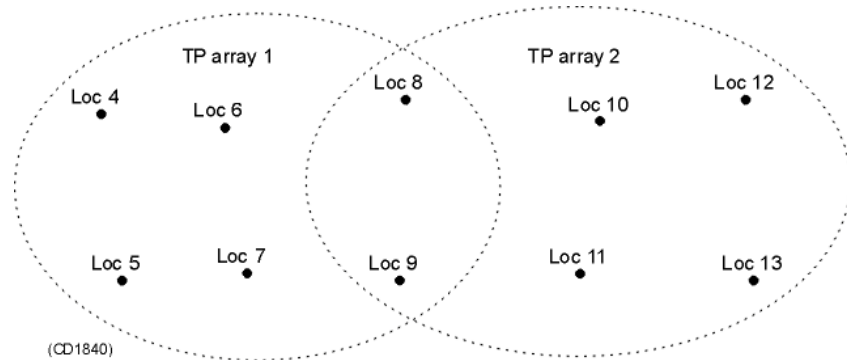

Figure 2 Two TP arrays with overlapping locations

All range measurements for the local calibration are performed within the TP arrays. When finished with the measurements in one TP array, a calculation using only those measurements should be performed to check the measurements. Then, only the locations specified as being part of the actual TP array receive new calibrated positions. The positions of the other locations will remain at their initial values. Normally, some of the locations receiving new calibrated positions will also be used in other TP arrays. The new positions will then also be valid for those arrays, i.e. one location has one and only one position, even when used in more than one TP array.

When the ranges are measured in all the TP arrays with overlapping locations, a local calibration calculation for the super array should be performed. The range measurements performed in all the TP arrays are then used, and all locations receive new calibrated positions.

Geographical coordinates

Many LBL applications do not use geographical coordinates. For those applications, you may ignore this chapter.

The APOS may receive geographical positions from a DGPS receiver, and it may present the calculated LBL positions in geographical coordinates.

Geographical coordinates are always referred to a datum defining the ellipsoid model of the earth. The APOS may work with three datum simultaneously. They are:

1. **A reference datum.** This datum is used by the HiPAP / HPR system in the internal calculations. It is by default WGS 84, and you should not change it.
2. **A GPS datum.** This datum is the one used by the DGPS receiver. After having received a geographical position from the DGPS receiver, the HiPAP / HPR system converts the position to the reference datum before starting any calculations. You may select the GPS datum from a list of datum in a menu.
3. **An APOS datum.** This datum is used by the HiPAP / HPR system when presenting LBL positions in geographical coordinates, both on the screen, in printouts and in binary telegrams. You may select the APOS datum from a list of datum in a menu.

The system always performs the LBL calculations in local coordinates. If the LBL positions are to be presented in geographical coordinates, the transformation from local to geographical is performed just before the presentation. The APOS must know the geographical coordinates of the local origin and the rotation of the local north axis to perform this conversion.

When the initial coordinates for the locations are entered in UTM coordinates, the APOS must convert the position to local coordinates before performing any calculations. To perform this conversion, it must know the geographical coordinates of the local origin to be used. That is inserted by you as a UTM centre. The rotation parameter of this origin is calculated automatically to the angle between the geographical north and the UTM north. You should not change the UTM centre when it is in use for the locations.

The use of the UTM centre as an origin is similar to the use of the origin calculated in a geographical calibration.

The UTM centre or the origin calculated in the geographical calibration may be transferred to the origin(s) of the TP array(s). When transferred to a TP array, the origin is used when:

- Positioning in the TP array. The LBL position calculated may be presented in UTM or in geographical coordinates.

- Printing the calibrated positions of the locations. The calibrated positions are always printed in local coordinates. Those locations used in a TP array with an origin are also printed in UTM coordinates.

Quality control of the data

The quality control of the data is performed on many levels. The HiPAP / HPR system measures more than is strictly necessary, and thereby gains the possibility to check the quality of the results.

Local calibration

The calibration is primarily based on range measurements between the transponders. Each range is measured many times, and the program calculates a standard deviation on each range. You may examine the measurements, and the ranges may be measured anew. You may exclude ranges from the calibration calculations if no acceptable standard deviation is obtained.

The inverse of the standard deviations are used by the algorithms as weights when calculating the optimum transponder array positions.

After having calculated optimum positions for the array transponders, the APOS checks how the measured ranges fit with the calculated positions. Ranges that do not fit well have large range residuals, and these ranges may be measured anew or excluded before the calibration calculations are performed again.

The APOS calculates the uncertainties of the calibrated positions, and presents them as error ellipses around the positions.

Geographical calibration

The APOS uses positions of the vessel, simultaneously received from a DGPS system and calculated by the LBL system, as the basis for the geographical calibration. Only two DGPS / LBL position pairs are necessary to calculate the origin latitude, longitude and rotation, but up to many hundreds position pairs may be logged and used in the weighted least square error calculation. The calculation is over determined, and distance residuals are calculated for each position pair. The RMS value of these residuals indicate how well the position pairs match.

Each position pair has associated statistical information indicating its uncertainty. This information is used in the calculations, and it contributes to the statistical data giving the uncertainty of the origin calculated.

Positioning

During positioning the HiPAP / HPR system normally measures more ranges and SSBL directions than is necessary. After having calculated the position, it checks how well the measured ranges and directions fit with the position. Measurements obviously wrong may be automatically excluded when the position is calculated again.

The APOS calculates residuals of all measurements, and the uncertainty of the LBL position

The uncertainty of the local LBL position calculated, depends on several factors:

- The number of ranges and SSBL angles measured, and the geometrical crossings of the vectors from the transponders to the transducer.
- The accuracy with which the ranges and the angles are measured.
- The uncertainty of the sound velocity profile used. You insert this uncertainty in a menu.
- The uncertainty of the calibrated positions of the transponders in the array.

The local LBL positions calculated may be presented in geographical coordinates. In that case, the uncertainty of the origin is statistically added to the uncertainty of the local position before being presented. (The graphical presentation on the screen is always in local coordinates. The printouts however may be in geographical coordinates.)

Transponder Modes

Each transponder may be in one of the following modes.

- *SSBL mode*. The transponder enters this mode after power on and after reset. It must be in this mode when being interrogated as an SSBL transponder.
- *LBL calibration mode*. The transponder must be in this mode when performing the subsea range measurements during the Local calibration.
- *LBL positioning mode*. The transponders must be in this mode when measuring ranges from a transducer to the transponders. In this mode, the transponder is interrogated on an LBL interrogation channel, which is usually different from the transponder's channel. The transponder's reply frequency is decided by its channel number. This mode enables all the transponders in an array to be interrogated on the same interrogation channel, while replying on their individual frequencies.

In the LBL positioning mode, the turnaround delay is set individually for each transponder. This possibility is used to prevent the transponder replies being received at the transducer simultaneously.

Operation

The following paragraphs give an overview of the operations without going into details. For detailed description of the operation, refer to the APOS on-line help system.

Measure ranges

The transponders in the transponder array must all be in the Calibration mode before the subsea ranges are measured.

The local calibration is primarily based on range measurements between the transponders. They send the results up to the HiPAP / HPR system by telemetry. You may choose to request one transponder at a time to measure the ranges to all the others, or you may request all the transponders, one at a time, to measure the ranges to all the others. This operation will last for some minutes, depending upon the ranges and the number of ranges to measure. The second option should only be selected when the vessel has good telemetry communication with all transponders from a single position. In both cases only one telemetry function is performed at any one time in the water.

Execute the local calibration

Once the subsea ranges have been measured, the positions of the transponders in the array can be calculated.

When the APOS has completed the calculations, it displays the maximum and the RMS values of the range residuals. These indicate how well the calibrated positions fit with the measured ranges. If you are not satisfied with the residuals, you should identify the ranges contributing the most to the RMS value of the residuals. Ranges with large residuals should be measured again and the calibration calculations repeated. This iteration may need to be performed many times before the resulting residuals are considered to be small enough.

The left part of the screen is normally used to present graphical information. In the LBL local calibration process, it is better to use it to display the ranges. Then the display gives an overview over the ranges, the standard deviations and the range residuals. The ranges and the standard deviations are updated after each range measurement. The range residuals are updated after each local calibration calculation.

Position a vessel or ROV

When satisfied with the result of the local calibration, you can start the positioning operation. First the turnaround delays of those transponders in the array must be decided, then the transponders must be commanded to the LBL positioning mode.

Position a transponder

The transponders are able to measure the ranges to other transponders, and send the result, on telemetry, to the HiPAP / HPR system. This capability is used in the LBL transponder positioning mode. The transponder to be positioned is called the master transponder, and it is not part of the TP array. The master transponder measures ranges to transponders in a TP array, these other transponders being called the slaves. Up to six slaves may be used simultaneously by one master. The transponders in the TP array must be in the calibration mode. The master is commanded to be in a special TP range positioning mode, in which it knows the channels of the slaves to which it is to measure the ranges. The positioning sequence is initiated by the HiPAP / HPR system transmitting a short message to the master on telemetry. The master measures the ranges to the slaves, just as in calibration mode. Only one range is measured towards each slave. When it has finished, the master transmits the ranges, on telemetry, up to the HiPAP / HPR system, then waits for the next request to measure ranges.

The LBL transponder positioning mode is a flexible and simple solution for many applications. The drawback is the speed. Both the ranges and the request to measure are sent on telemetry, and the master transponder measures only one range at a time. The time used for a sequence depends on the number of slave transponders used, and if there are timeouts on the replies from the slaves. The positions may be updated as fast as once every 12 seconds, though more time may well be required, resulting in a slower update rate.

Geographical calibration

The geographical calibration requires that you position the vessel in local LBL coordinates and that the APOS reads the vessel position from a DGPS receiver simultaneously. An LBL position and a DGPS position, logged simultaneously, are named a position pair.

When logging the position pair, the vessel should be drifting to avoid noise and air bubbles from the thrusters and propellers disturbing the LBL measurements. 8 to 10 position pairs should be logged while the vessel is drifting in one position, then the vessel should be moved to another position and a new 8 to 10 position pairs should be logged. This procedure should be repeated at many positions, evenly distributed, in the area covered by the transponder array. Do not log only while located in the centre of the area as that will give a high uncertainty for the rotation of the local north axis.

When logging position pairs, attention should be paid to the ranges measured and the range residuals calculated. The best results are achieved when the position pairs are logged when many ranges are measured correctly and their residuals are small.

When enough position pairs are logged, the geographical calibration calculation is performed. Some position pairs will often have larger distance residuals than the others. In that case, you may exclude some of the position pairs with the large distance residuals and repeat the calculation. When performing the exclusions, be aware that the position pairs used in the calculation should be evenly distributed in the area.

SSBL PRINCIPLES OF OPERATION

Introduction

For Super-Short Base Line (SSBL) information please refer to the *HiPAP / HPR 400 Product description* – section in the APOS HiPAP / HPR 400 Instruction manual.

Blank page

HPR 400 series

This document describes HPR 400 acoustic positioning systems. The HPR 400 series consists of HPR 410, HPR 408 and HPR 418 systems, which covers SSBL, LBL and combined SSBL and LBL modes of operation.

Note

Kongsberg Maritime AS makes every effort to ensure that the information contained within this document is correct. However, our equipment is continuously being improved and updated, so we cannot assume liability for any errors which may occur.

Warning

The equipment to which this manual applies must only be used for the purpose for which it was designed. Improper use or maintenance may cause damage to the equipment or injury to personnel. The user must be familiar with the contents of the appropriate manuals before attempting to operate or work on the equipment.

Kongsberg Maritime AS disclaims any responsibility for damage or injury caused by improper installation, use or maintenance of the equipment.

Copyright

©2003 Kongsberg Maritime AS

The information contained within this document remains the sole property of Kongsberg Maritime AS. No part of this document may be copied or reproduced in any form or by any means, and the information contained within is not to be communicated to a third party, without the prior written consent of Kongsberg Maritime AS.

Kongsberg Maritime AS

Strandpromenaden 50, P.O.Box 111, N-3191 Horten, Norway

Telephone: +47 33 03 44 00, Telefax: +47 33 04 47 53

www.kongsberg.com

subsea@kongsberg.com



KONGSBERG

Document revisions

Rev	Date	Written by	Checked by	Approved by
A	22.09.97	JEF	HPJ	JEF
B	29.01.98	JEF	HPJ	JEF
C	10.03.98	GM	HPJ	JEF
D	24.05.00	GM	HPJ	JEF
E	27.08.03	GM	THG	JEF

(The original signatures are recorded in the company's logistic database)

References

Guide – line for HPR performance calculations.....	859-160703
Attitude Format Description	853-201392

Contents

INTRODUCTION	1
General.....	1
List of abbreviations.....	1
HPR 400 systems	2
HPR 400 portable system.....	2
APOS.....	3
Sensors	3
POSITING PRINCIPLES	4
SSBL Positioning.....	4
LBL Positioning.....	6
Calibration	6
Positioning.....	6
Combined SSBL and LBL positioning.....	8
Multi-User LBL positioning	8
MEASUREMENT COMPENSATION	10
Roll - pitch - heading compensation	10
Ray bending compensation	11
Transducer alignment.....	11
APPLICATIONS	14
Interfaces to HPR 400 system.....	14
Dynamic positioning reference	14
Subsea survey and inspection	14
Rig monitoring	14
Acoustic Blow Out Preventer (BOP) Control.....	15
Construction work and metrology.....	16
LBL Transponder positioning	16
LBL High Accuracy Metrology	16
SYSTEM UNITS.....	17
Introduction.....	17
HPR 400 series	18
Operator station.....	19
Introduction	19
Operator station configuration.....	20

Standard operator station.....	20
Integrated operation with SDP XX.....	21
Units.....	21
Transceiver unit.....	21
Transducers.....	23
Hull units.....	23
Hoist control unit.....	23
Remote control unit.....	24
Gate valves.....	24
Mounting flange.....	24
EXTERNAL INTERFACES.....	25
Vertical Reference Unit (VRU).....	25
Gyro compass.....	25
Integrated attitude sensors.....	25
Interface specification.....	25
SYSTEM CONFIGURATIONS.....	26
Introduction.....	26
Single HPR 400 system.....	26
Redundant HPR 400 system.....	26
Combined HiPAP and HPR 400 system.....	26
Single HPR 400 - system diagram.....	27
Redundant HPR 400 - system diagram.....	28
Transceivers.....	29
Transducers.....	29
TRANSPONDERS.....	30
General.....	30
MPT series.....	31
SPT series.....	32
MST series.....	33
SYSTEM FUNCTIONS.....	34
Introduction.....	34
Main functions.....	34
General.....	34
List of main functions.....	35

TECHNICAL SPECIFICATIONS	40
SSBL Accuracy.....	40
LBL accuracy.....	40
Range capabilities	41
Unit specifications.....	42
APC 10 computer	42
WinKeyboard	43
Display 17.4" TFT.....	43
HPR 400 transceiver unit	44
Hoist control unit.....	45
Remote control unit.....	45
Flange.....	46
Gate valve.....	47
Outline dimensions.....	48
APC 10 computer.....	48
WinKeyboard	49
17.4" TFT display.....	50
Operator console	51
HPR 400 transceiver – 19" rack.....	52
HPR 400 transceiver – 6u cabinet.....	53
HL3880 / HL3100 / HL2300 / HL1530	54
Hoist control unit.....	55
Remote control unit.....	56
HL 3380 Ex – 1	57
Relay unit Ex – 1	58
Local control unit Ex – 1	59
Remote control unit Ex – 1	60
Standard transducer.....	61
Narrow /LF Medium beam transducer	62
Gate valve and flange – 500 mm.....	63
Gate valve and flange – 350 mm.....	64

Document history

(The information on this page is for internal use)

- Rev. A** Initial issue.
- Rev. B** Updated with HiPAP®.
- Rev. C** Layout/fonts updated. HiPAP transceiver IP set to IP 44, LBL accuracy included.
- Rev. D** Implemented new drawings of the DN500 and DN350 mounting flanges. Updated figure SSBL PRINCIPLE.
- Rev. E** Removed HiPAP information. Updated transponder information. Implemented HPR 400 Subsea unit.
The document describes only HPR 400 series. Ref. EM 855-201391E.

Blank page

INTRODUCTION

General

This document covers the HPR 400 series. It provides a general description of the systems, each module, the functions and technical specifications.

List of abbreviations

ACC	Acoustic Control Commander
ACS	Acoustic Control Subsea
APC	Acoustic Positioning Computer
APOS	Acoustic Positioning Operator Station
BOP	Blow Out Preventer
DGPS	Differential Global Positioning System
DP	Dynamic Positioning
GPS	Global Positioning System
HiPAP	High Precision Acoustic Positioning
HPR	Hydroacoustic Position Reference
LBL	Long Base Line
LF	Low Frequency
MF	Medium Frequency
MST	Mini SSBL Transponder
MPT	Multifunction Positioning Transponder
ROV	Remotely Operated Vehicle
SPT	SSBL Positioning Transponder
SSBL	Super Short Base Line
VRU	Vertical Reference Unit

HPR 400 systems

The HPR 400 series of acoustic positioning systems integrate SSBL, LBL and combined SSBL / LBL positioning principles on the same hardware and software platform. The systems can be configured to be one or a combination of the principles as follows:

- **HPR 410 SSBL system** - Uses SSBL type of transducer(s). Positions target(s) relative to vessel. It can be used with a selection of transponders. Acoustic telemetry is available.
- **HPR 408 LBL system** - Uses LBL type of transducer(s). Position surface vessel or ROV relative to local seabed transponder array. Provides data both in local and UTM coordinates. Can be used with a selection of LBL transponders. Uses acoustic telemetry for array calibration.

The HPR 408 LBL system can also be delivered with a subsea transceiver. This system may be used for Remotely Operated Vehicle (ROV) LBL positioning, as well as for any other subsea module positioning requiring LBL accuracy. Available subsea units:

- HPR 400 S31 - This is a MF system, and is deep water rated to 1000 meter.
 - HPR 400 S33 - This is a MF system, and is deep water rated to 3000 meter.
 - HPR 400 S16 - This is a LF system, and is deep water rated to 6000 meter.
- **HPR 418 SSLBL system** - Uses SSBL type of transducers. Combines features from both SSBL and LBL. Position surface vessel or ROV relative to local seabed transponder array and/or target relative vessel. Provides data both in local and UTM coordinates. Combined algorithm uses both ranges and directional measurements to compute the position. Can be used with a selection of transponders. Uses acoustic telemetry for array calibration.

HPR 400 portable system

The HPR 400 series also consists of a portable system, which has the same functionality as the above systems. The portable system has some limitations and is not for use with a Dynamic Positioning system. The portable system is not described here.

APOS

The HPR system is operated from the APOS, which is a Windows XP based software.

The APOS software can also be integrated with the Kongsberg DP system.

Sensors

The HPR system has a wide range of interfaces to sensors from different manufacturers. A gyro-compass and a vertical reference sensor will normally be interfaced to the system.

POSITINING PRINCIPLES

SSBL Positioning

In SSBL, the HPR system calculates a three-dimensional subsea position of a transponder relative to a vessel-mounted transducer. The position calculation is based on range and direction measurements to one transponder. The onboard transducer transmits an interrogation pulse to a subsea transponder, which then answers with a reply pulse.

- The onboard system will measure the time from interrogation to the reply pulse is detected and use the sound velocity to compute the range.
- The transponder position is presented both numerical and graphically on the operator station. Only one onboard SSBL type transducer is necessary to establish this position.

Using a pressure sensor in the subsea transponder can increase position and depth accuracy. The water pressure is measured and transmitted to the surface HPR system using telemetry. The depth is then used in the algorithms for establishing the 3D position. The system can also read the depth via a serial line input from a pressure sensor. Simultaneous use of many transponders is made possible by utilising individual interrogation and reply frequencies.

SSBL PRINCIPLE

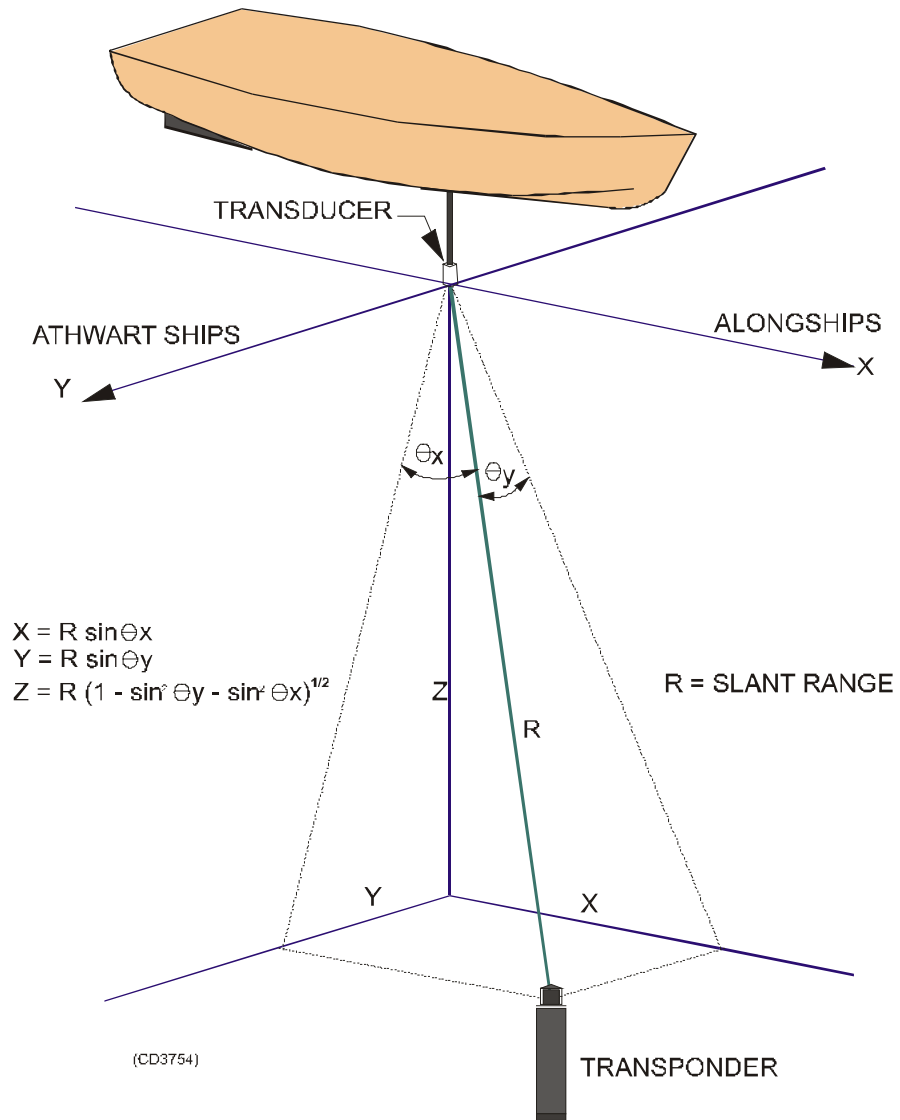

LBL Positioning

Calibration

The LBL principle is based on one vessel-mounted transducer, and normally 4 - 6 transponders on the seabed. This seabed transponder array must be calibrated before LBL positioning operations can begin. The calibration shall determine the transponder's positions in a local geographical coordinate frame. The HPR 400 system supports two calibration techniques:

Baseline measurements

This technique uses automatic calibration functions in the HiPAP system. This allows all the ranges to be measured and made available by acoustic telemetry communication between the transponders and the vessel's system. Based on the baseline measurements and initial positions of the transponders, the calibrated transponder positions are computed.

Runtime calibration

To use this technique, the system is run in LBL positioning mode, using the SSBL positions of the seabed transponders for the vessel LBL position calculation. The runtime calibration function logs the measurements, and based on this, new optimised seabed transponder positions will be computed. This technique makes the baseline measurements redundant. If the baselines measurements are done, they are also used in the calculations.

The calibration is performed only once prior to positioning operation, since the transponders will remain in the same location during the operation.

Positioning

When the transponder positions are known, positioning of the surface vessel can begin. All the seabed transponders will be interrogated simultaneously, and each will respond with its specific reply signal. The LBL system will then calculate the ranges from the individual transponders. By using the calibration data together with the calculated ranges in software algorithms, the vessel or an ROV can be positioned.

- The system can take the depth from an ROV-mounted pressure sensor via a serial line. By using this depth in the computation, it will increase the position accuracy of the ROV.

- The range capabilities of a medium frequency LBL system will be approximately the same as those of an SSBL system.
- LBL positioning is more complex to operate, it needs more transponders than the SSBL, but it will give better position accuracy at greater distances.

LBL PRINCIPLE

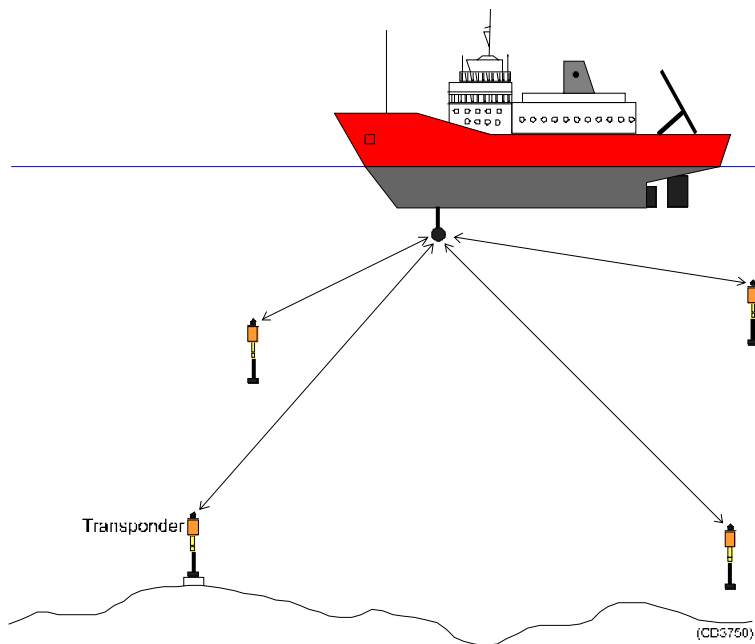

Combined SSBL and LBL positioning

The combined SSBL / LBL system uses an onboard multi-element transducer. The system may operate as an SSBL system and as an LBL system simultaneously.

As an example, the vessel may be positioned relative to the seabed using LBL while a SSBL transponder on a ROV is positioned relative to the vessel. The vessel is displayed relative to the LBL transponder array origin and the ROV relative to the vessel

The combined system will also use the measured angles together with the measured ranges in the LBL positioning. The combined measurement gives a robust system with increased accuracy. An LBL solution is achievable when only two transponder replies are detected.

Multi-User LBL positioning

Several individual vessels and ROV units can now position themselves using the same seabed transponder array. The system and principle has the following main advantages:

- Provides high position accuracy (comparable to standard LBL).
- A small number of transponders serve all vessels and ROVs.
- Secures high position update rate (down to approx. 2 seconds), which is essential in DP operations.
- Avoids transponder frequency collisions when vessels are working in the same area (all vessels are "listening" only).

A transponder array is deployed and calibrated by use of subsea baseline measurements. One transponder is used as the Master in the positioning phase. The other transponders are called the Slaves.

The Master transponder acts as a beacon. It starts a positioning sequence by doing the steps described below. This is done regularly with an interval set by telemetry from one of the vessels.

- 1 The Master interrogates the Slaves.
- 2 The Master transmits its individual transponder channel to be received by the vessels/ROVs positioning in the array.
- 3 Each Slave transponder receives the interrogation from the Master and transmits its individual reply channels after a turnaround delay.

A MULBL system positioning in the array, listens for the individual channels transmitted by the master beacon, and by the Slave transponders. When they are received, the system uses its knowledge about their positions in the TP array to calculate the differences in range to the transponders in the TP array. The time difference between the Master interrogation and the start of the reception of the pulses at the system is unknown. It has to be calculated together with the position of the vessel or ROV.

All vessels to use the MULBL array need the coordinates of the transponders and the channel numbers, which will be distributed of a file.

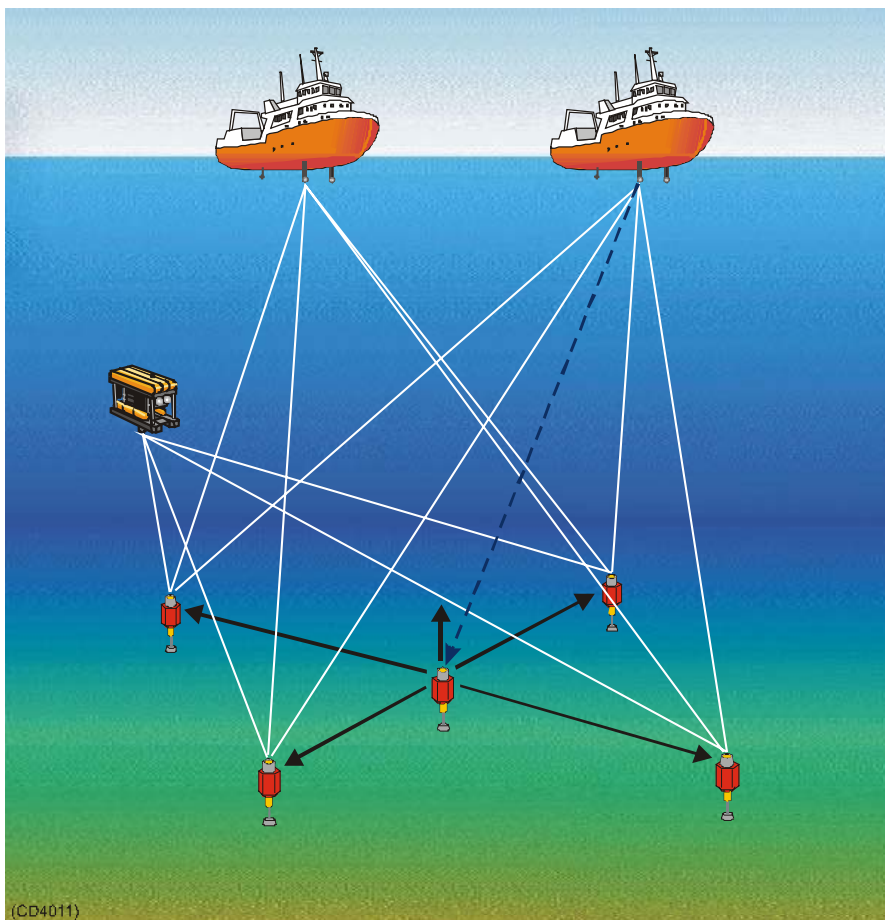

MEASUREMENT COMPENSATION

Roll - pitch - heading compensation

In order to compensate for the vessel roll/pitch/heading movements, vertical reference sensors and heading sensors are interfaced. Data from these sensors are used to compute position data that is relative to horizontal level and to north.

The absolute accuracy and the standard deviation of the position are very dependent of the roll/pitch/heading sensors performance. Specially when working at great waterdepths the roll/pitch/heading error contribution is significant and when working at long horizontal range the heading error contribution is significant. This compensation is used in all positioning modes.

The accuracy of the attitude data is of crucial significance for the total accuracy of the HPR system, and the error from the attitude sensor will add to the error of the HPR system.

As an example an roll or pith error of 0.25 degrees will give an error of 4.4 m at 1000 m depth, and an error of 13 m at 3000 m depth, while a roll or pitch error of 0.05 degree will give respectively 0.9 m and 2.6 m.

Ray bending compensation

Ray bending compensation is done in the Operator Unit. The positions calculated from the raw measurements are influenced by variable sound velocity through the water column. The system can correct these errors.

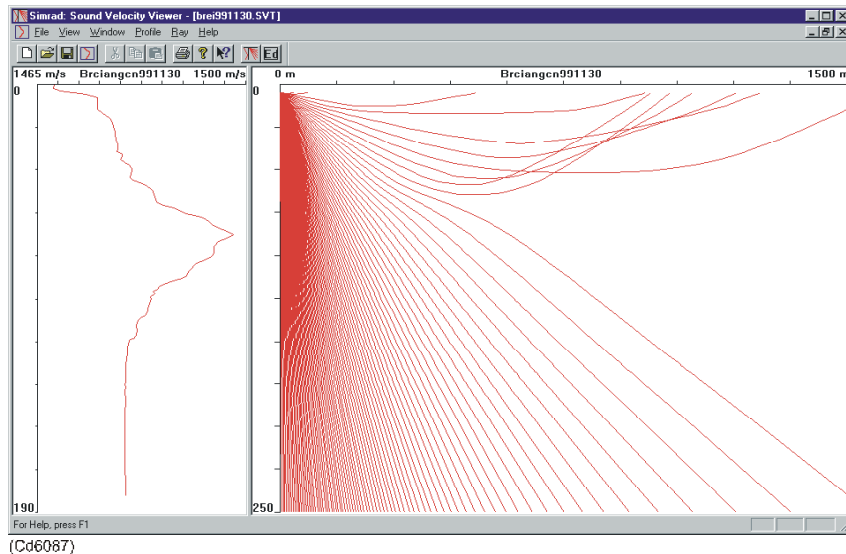

The sound velocity values may be measured by a probe and transferred to the system. If the depth of the target (transponder) is known either by depth sensor in the transponder or by an ROV depth sensor, these data can be transferred to the system.

The range calculation is compensated for the error caused by different sound velocities in the water column, and for the extra propagation path caused by the ray bending. The compensation is used in all positioning modes.

Transducer alignment

After the installation, it is necessary to determine a number of offsets between various sensor reference points and axes. These are:

- Vertical angular - The offset between transducer axis and roll/pitch sensor axis.
- Horizontal angular - The offset between roll/pitch sensor and heading reference.
- Horizontal angular - The offset between transducer axis and heading reference.

- Horizontal distance - The offset between transducer location and reference point.

The principles for these alignment adjustments are based on the position of a fixed seabed transponder relative to the vessel and the geographical position of the vessel.

In order to simplify and improve the quality of the alignment scenario, the alignment function in APOS is used. By logging the vessel position from DGPS along with the measured position of a seabed transponder, the program computes the alignment parameters. The normal procedure is to locate the vessel at four cardinal points and on top of the transponder with four headings.

Immediately the alignment parameters can be computed and automatically be transferred to the APOS alignment parameters. No manual transfer is needed. The results from the alignment are shown both numerical and graphically on the APOS. An example is shown in the two figures below.

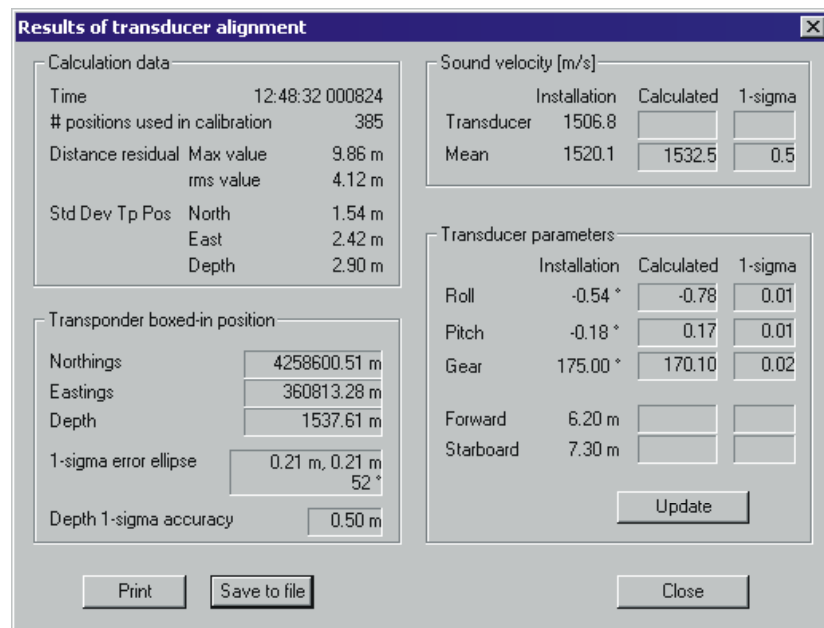

(C:\d5988)

Figure 1 Result of transducer alignment – APOS presentation

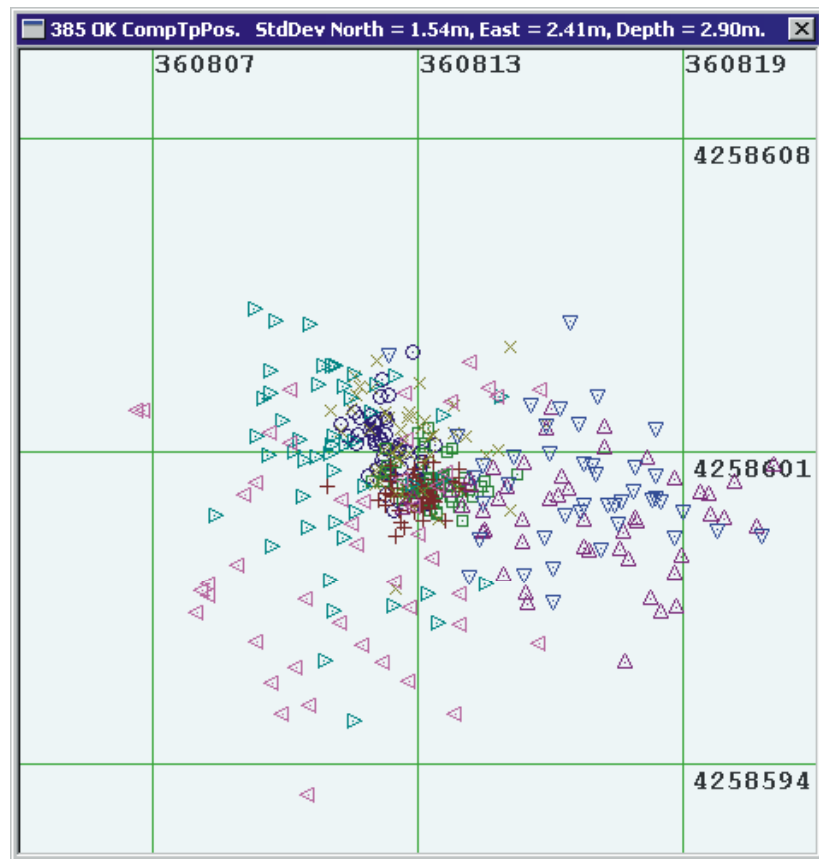

(Cd5885)

Figure 2 Transponder positioning - APOS presentation

The figure shows the positions at the seabed transponder in UTM coordinates after the compensation values are determined and applied. The various symbols are used so readings from different locations easy can be separated from each other.

APPLICATIONS

Interfaces to HPR 400 system

The HPR 400 can be interfaced to other computers allowing them to process the position data for various applications. The system is flexible in the way it interfaces other computers. Several binary and ASCII formats are available on serial line and Ethernet using UDP protocol. A dual Ethernet is available for secure DP operations. An accurate time-tagged position output is available if the system is interfaced to a DGPS and synchronised to 1PPS.

Dynamic positioning reference

The position data can be used by a Dynamic Positioning (DP) system as the reference signals for keeping the vessel in the desired position. High position accuracy and reliability ensure a secure and stable reference input to the DP systems. SSBL, LBL and SSLBL systems may be used.

Subsea survey and inspection

Positioning of ROVs carrying instruments for survey and inspection is another important application for the HPR systems. The ROV position relative to the vessel is integrated with the position from surface navigation to provide a geographical position of the ROV. In this application a responder is suitable.

Tracking towed bodies for similar applications may also be done. In survey applications, a best possible geographic position is wanted. To obtain this, sound velocity and pressure sensor input to the HPR may be used.

Rig monitoring

The HPR 400 systems can be used to monitor the drill rig position relative to the well/BOP. It can also be used with inclinometer transponders to monitor the BOP and riser inclination. Used with the ACS 400 it can be used for acoustic BOP control.

Acoustic Blow Out Preventer (BOP) Control

The HPR system is also used for transmitting and receiving acoustic telemetry command with high security. This is used for:

- Acoustic BOP control.
- Opening and closing of a valve governing the flow of crude oil to a tanker as on OLS.
- Monitor critical functions by reading subsea status information and sending this information to the operator onboard the vessel.

A separate system, ACS, is required on the BOP stack. A portable control unit, ACC, is also available.

Construction work and metrology

LBL Transponder positioning

A feature in the HPR system is to position one transponder relative to an LBL array. One Multifunction Positioning Transponder (MPT) is used to measure the range to other MPTs in an LBL array, and to transmit the ranges via telemetry to the surface HPR system. The HPR system computes the position of the transponder in the array.

The transponders may be interrogated simultaneously or in sequence. The ranges can be transmitted automatically after the measurement or on a controlled sequence from the surface HPR system.

The operator can control the speed of the telemetry link. A position update rate of 4 seconds is achievable. This function is ideal in applications like subsea construction and other object positioning where high accuracy is required and where there is no possibility to have an umbilical.

LBL High Accuracy Metrology

The MPT transponders have a High Accuracy mode, which has a very good range accuracy performance. It is possible to measure baselines with accuracy better than 0.05 m. The MPT's are standard units that are operated by the HPR system.

The high accuracy and range capabilities obtained using MPT units in medium frequency mode reduces the need for high frequency transponders. High frequency transponders often need additional equipment to be installed onboard.

SYSTEM UNITS

Introduction

The HPR 400 system consists of 3 different main units:

- Operator station
- Transceiver
- Hull unit with transducer and hoist control.

A system may be configured with one or several of these units. A gyrocompass and a vertical reference sensor will normally also be included in an HPR 400 system.

The units for Operator station alternatives are shown in system diagrams and in the “Outline dimensions” chapter.

The HPR 400 series may be supplied with several alternatives for transceivers, transducer and hull units. An overview of the available modules is shown in the figure on the following page.

HPR 400 series

Operator Station alternatives

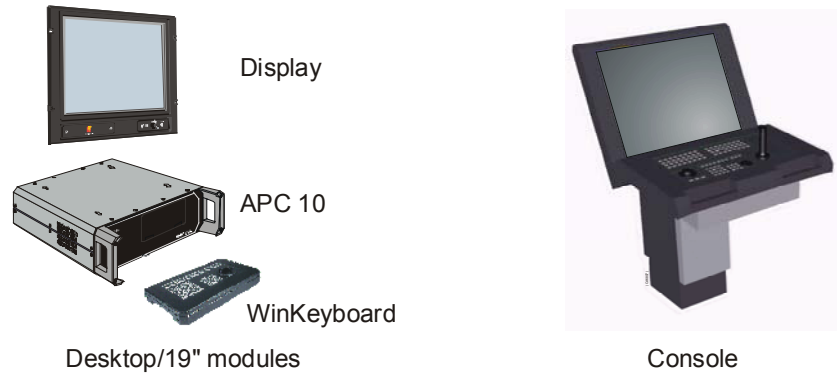

HPR 400 Transceiver alternatives

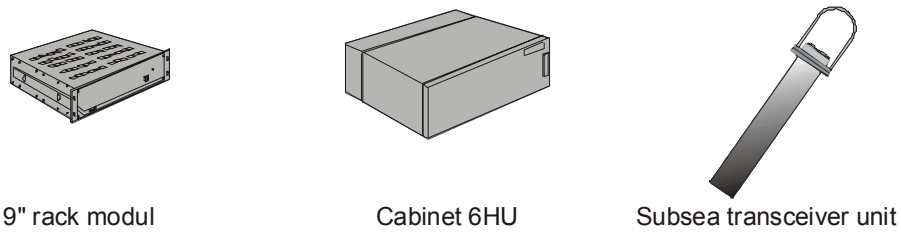

Hull unit alternatives

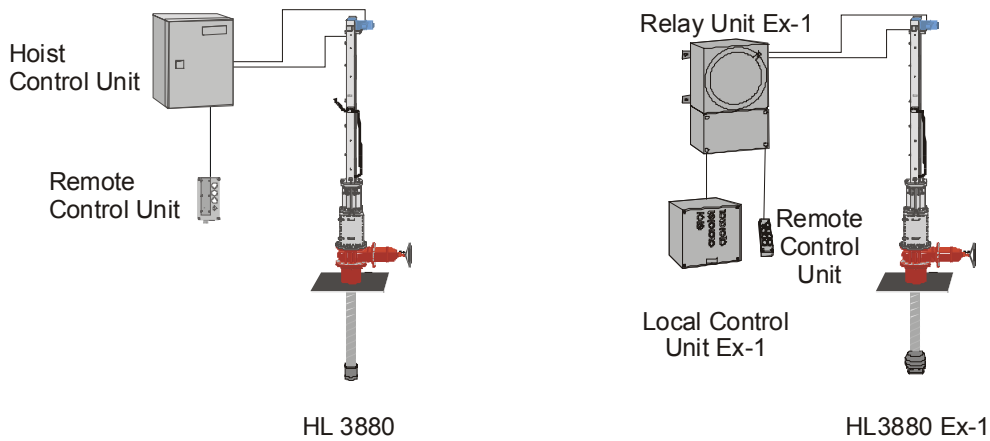

Transducer alternatives

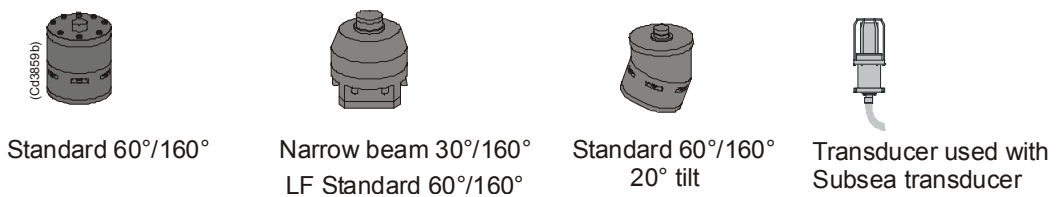

Operator station

Introduction

The Operator station consists of:

- APC 10 computer
- WinKeyboard
- Colour monitor

The computer runs on the Microsoft Windows XP operating system. The user interface is a graphical user interface, designed as a standard Windows XP application.

A WinKeyboard with numerical keys and a trackball controls the operation.

The screen is divided into 3 windows in which the operator can select several different views. Typical views are graphical position plot, numerical data, inclination and roll, pitch and heading. A normal display configuration is shown in the following figure.

One system may have one or several operator stations, which communicates on an Ethernet. One of the operator stations will be the Master. This is selected by the operator(s).

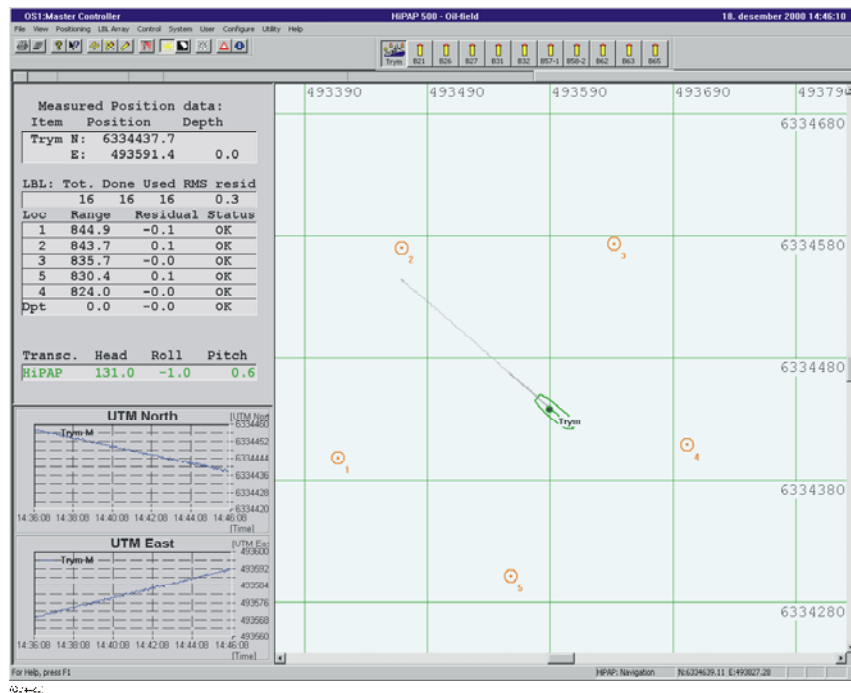

One system may have one or several operator stations, which communicates on an Ethernet. One of the units will be the master, which is selected by the operator(s).

Operator station configuration

The HPR system may be configured with the operator station in three ways:

- Stand alone APC 10, a monitor and the WinKeyboard
- Operating Console
- Integrated application on the same operator console as the Simrad SDP 70X series DP.

Standard operator station

APC 10 - Acoustic Positioning Computer

The *APC 10* is the computer in the HPR operator station. It holds all the operational software, and interfaces to display, keyboard, printers, network and other peripheral devices as required. The unit is normally fitted with a 3.5" floppy drive. The APC 10 may be mounted attached to the colour monitor, in a 19" rack or on a "desk top".

LCD colour display

The LCD display, the 17.4" TFT is a general purpose, micro-processor based and digitally controlled display unit. The display can be installed in several ways; desktop, roof, panel or 19" rack.

Console monitors

The HPR system may be integrated in a console. The monitor will normally then be supplied by the console manufacturer. It should be a 17" monitor or larger, able to operate with 1240x1024 resolution at 60Hz refresh rate.

Keyboard

The keyboard is designed for easy use. It includes numerical keys, function keys and a trackball with three buttons. The keyboard can be mounted on the APC 10 or be put on a desktop.

Operator console

The operator console integrates a 21" monitor, system controller and a keyboard. The console is identical to consoles used with the Simrad DP systems. The console is to be mounted on the deck.

Integrated operation with SDP XX

The integrated HPR and DP operation is available as two different solutions.

HPR and DP - one operator station

The operator must select whether the HPR or DP shall be viewed and operated. This is eligible from the menu. When the DP window is active, the HPR can be accessed from the menu selecting the HPR view or accessing a dialogue box for transponder operation. When the HPR window is active, the DP can be accessed from the menu selecting DP view.

HPR and DP - multiple operator stations

When several operator stations are available, the operator can view/operate the DP on one/several screen(s) and the HPR on another screen. The operation is the same as for a single operator console.

Units

Transceiver unit

Introduction

The HPR 400 Transceiver Unit processes the acoustic signals, calculates the transponder position(s), processes the acoustic telemetry data, and sends the information to the APC 10. The unit is a 19"/3u rack module normally installed in a 6u cabinet for bulkhead mounting. It may also be delivered as a stand alone 19"/3u rack module. The main interfaces are:

- 2 SSBL transducers
- 2 LBL transducers
- 4 responders
- Roll, pitch and heading sensor.

The HPR 400 may be configured as a MF or LF system for all transducers. A combination of one MF and one LF SSBL transducer with one MF and one LF LBL transducer is also available.

The HPR 400 transceiver is also available in a subsea container rated for 3000 meters. It is designed for LBL positioning of ROVs. It is not further described here.

SSBL processing

The transceiver can operate two SSBL transducers with up to 56 transponders simultaneously. The unit measures the phase-difference between the SSBL transducer element groups, the propagation time and vessel roll, pitch and heading. From these measurements, the unit computes the X, Y and Z position of the transponder. The data is sent to the APC 10.

The HPR 400 system is capable of handling both HPR 400 channels and HPR 300 channels.

LBL processing

The transceiver can operate 4 LBL transducers. Normally it uses 1 transducer and up to 8 transponders. The LBL processing can also be done with SSBL transducers. The unit measures the propagation time and computes the range to the transponders in the array. vessel roll, pitch and heading is also measured. The data is sent to the APC 10.

Combined LBL and SBL processing

Combined LBL/SBL processing may also be used. Here up to 4 transducers may be used towards up to 8 transponders.

SSLBL processing

The SSLBL processing does both SSBL and LBL processing simultaneously, in which both ranges and direction to the transponders in the array are measured. It requires SSBL transducers.

Telemetry processing

The transceiver can operate 4 LBL transducers for telemetry. Simultaneously, it can use one transducer and communicate to one transponder. The telemetry processing can also be done with SSBL transducers. The unit transmits acoustic telemetry messages, and receives and decodes the acoustic telemetry message from the transponder. The data is sent to the APC 10.

Transducers

A standard transducer (medium/wide/narrow beam) is mounted on a hull unit installed in the keel of the vessel. The transducer has a multi-element array of transmission/reception elements, enabling both pulse and phase measurement for the calculation of the range and two axis angles to the transponder(s).

Hull units

Introduction

An important factor for good acoustic communication to transponders is the high quality hull units on which the HPR transducers are normally mounted. These hull units allow the transducer to be lowered, under either local or remote control, through the vessel's hull to a depth sufficient to minimise the effects of noise and air layers below the vessel.

The hull unit is installed on top of a gate valve, which can be closed during service and maintenance of the transducer. The hull units also hold the guide arrangement for keeping the transducer exactly aligned with the vessel.

Available hull units

The HL 3880 is the standard hull unit available for the HPR 400 systems.

The descriptions in this document also apply to the following hull units:

- HL 1030
- HL 1530
- HL 2300
- HL 3100
- HL 6230

These hull units are based on the same design as the HL 3880 Hull Unit system, but differ in total height, transducer design and transducer depth.

Hoist control unit

This unit holds the power supplies and control logic for the hoist and lower operation of the hull unit. It also has a local control panel for local control of the hoist/lower operation.

Remote control unit

This unit is normally mounted close to the display unit in the operation room. It allows remote control of the hoist and lower operation of the hull unit.

Gate valves

There are two different gate valves available with 500 mm aperture and 350 mm aperture. The valve is hand-wheel operated, delivered with electrical interlock for prevention of lowering the transducer into the gate.

As an option the gate valve can be delivered with an electrical actuator (electrical gate valve operation).

Mounting flange

There are two different flanges available with 500 mm aperture and 350 mm aperture. Standard height is 600 mm. Optional length is available on request.

It is equipped with the following sub units:

- Local control unit
 - This unit holds the power supplies and control logic for the hoist and lower operation. It also has a local control panel for local control of the hoist/lower operation.
- Remote control unit
 - This unit is normally mounted close to the display unit in the operation room. It allows remote control of the hoist and lower operation.

The HL 3880 Ex-1 is the hull unit prepared to be fitted in explosive zone 1. It is equipped with the following sub units:

- Local control unit
 - This unit is normally mounted close to the hull unit for local control of the hoist and lower operation. This particular version is designed for use in explosive zones.
- Remote control unit
 - This unit is normally mounted close to the display unit in the operation room. It allows remote control of the hoist and lower operation.

EXTERNAL INTERFACES

Attitude sensors are a common definition for roll, pitch, heave and heading sensors. The HPR 400 system has a wide range of interfaces to sensors from different manufacturers.

Vertical Reference Unit (VRU)

The Vertical Reference Unit (VRU) is interfaced to the HPR 400 Transceiver Unit. The system can thereby automatically compensate for the vessel's roll and pitch movements. The HPR system can use the same VRU as the Dynamic Positioning (DP) system (if one is fitted).

The Vertical Reference Unit may or may not be a part of the Simrad delivery. In any case, the unit is documented separately by the applicable manufacturer.

Gyro compass

The gyro compass supplies the HPR with the vessel's heading relative to north. The HPR may then provide transponder coordinates relative to north. It is also used to update the position filter as the vessel changes heading.

Integrated attitude sensors

These sensors integrate rate gyros, accelerometer and GPS to provide an accurate roll, pitch, heave and heading output. These sensors are superior to traditional gyros and VRUs. The HPR may be interfaced to such sensors.

Interface specification

The HPR has several interface formats available. These are described in "Attitude formats description".

SYSTEM CONFIGURATIONS

Introduction

The HPR 400 system may be configured in several different ways, from a single system to a redundant system with several operator stations. Some configurations are described below.

Single HPR 400 system

The single system includes the minimum units for a fully operational system. The communication from operator station and HPR 400 transceiver is a serial line. The data output from the system is also serial line. A system like this can be a HPR 410 or a HPR 418. See following system diagram.

Redundant HPR 400 system

The redundant system has two of each unit to secure continuous operation even with a single failure. This system has communication between HPR 400 transceiver and operator station on a dual Ethernet, which secures control of both transducers if one operator station breaks down. The communication to other computers may be via Ethernet or via serial lines. See following system diagram.

Combined HiPAP and HPR 400 system

A combined configuration uses the common operator station or consoles to operate both HiPAP and HPR 400 systems. Existing HPR 400 system may be upgraded to a combined system by adding the HiPAP Hull unit and transceiver. The operator can control both systems by using one operator station/console.

Single HPR 400 - system diagram

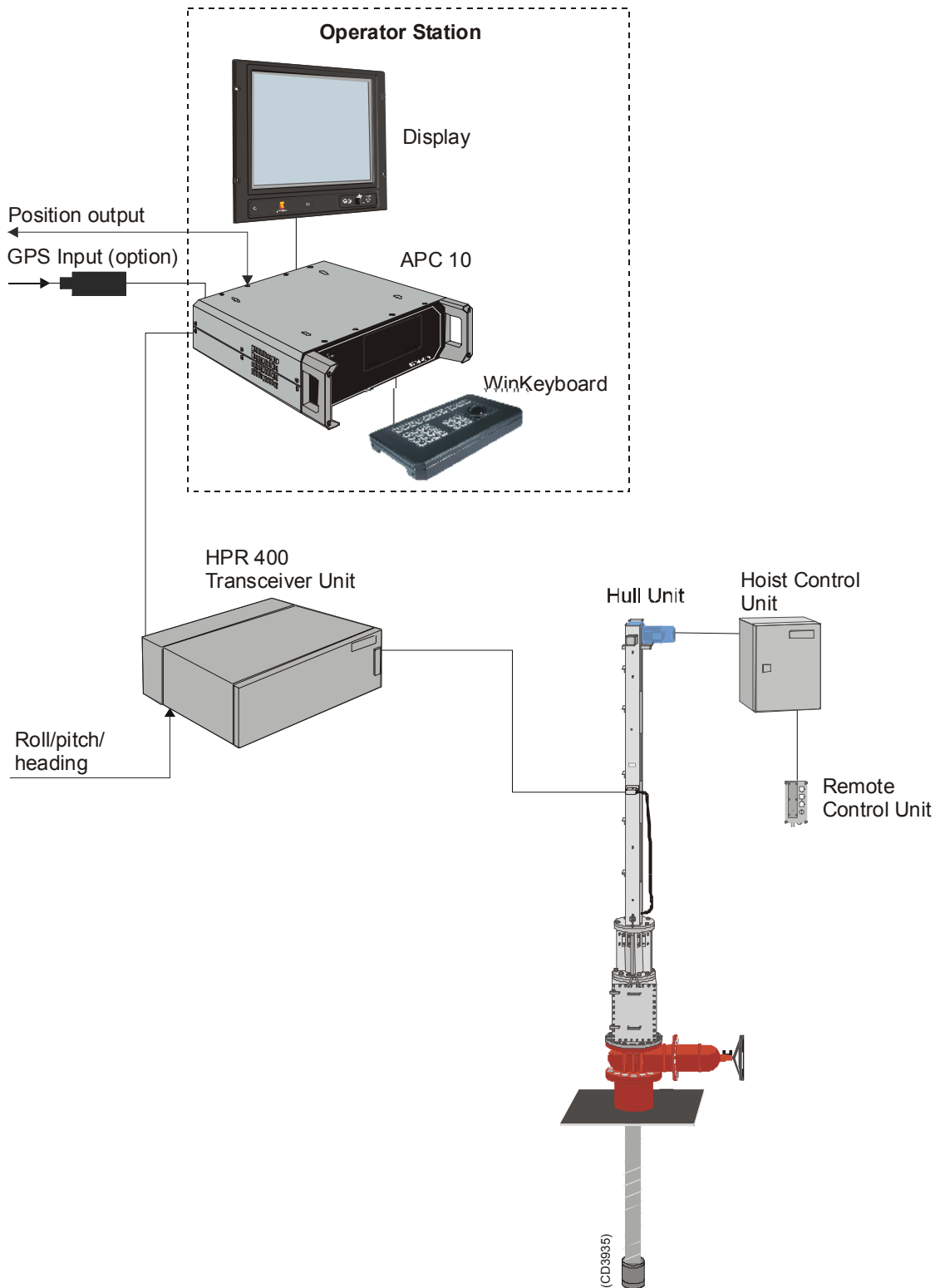

Redundant HPR 400 - system diagram

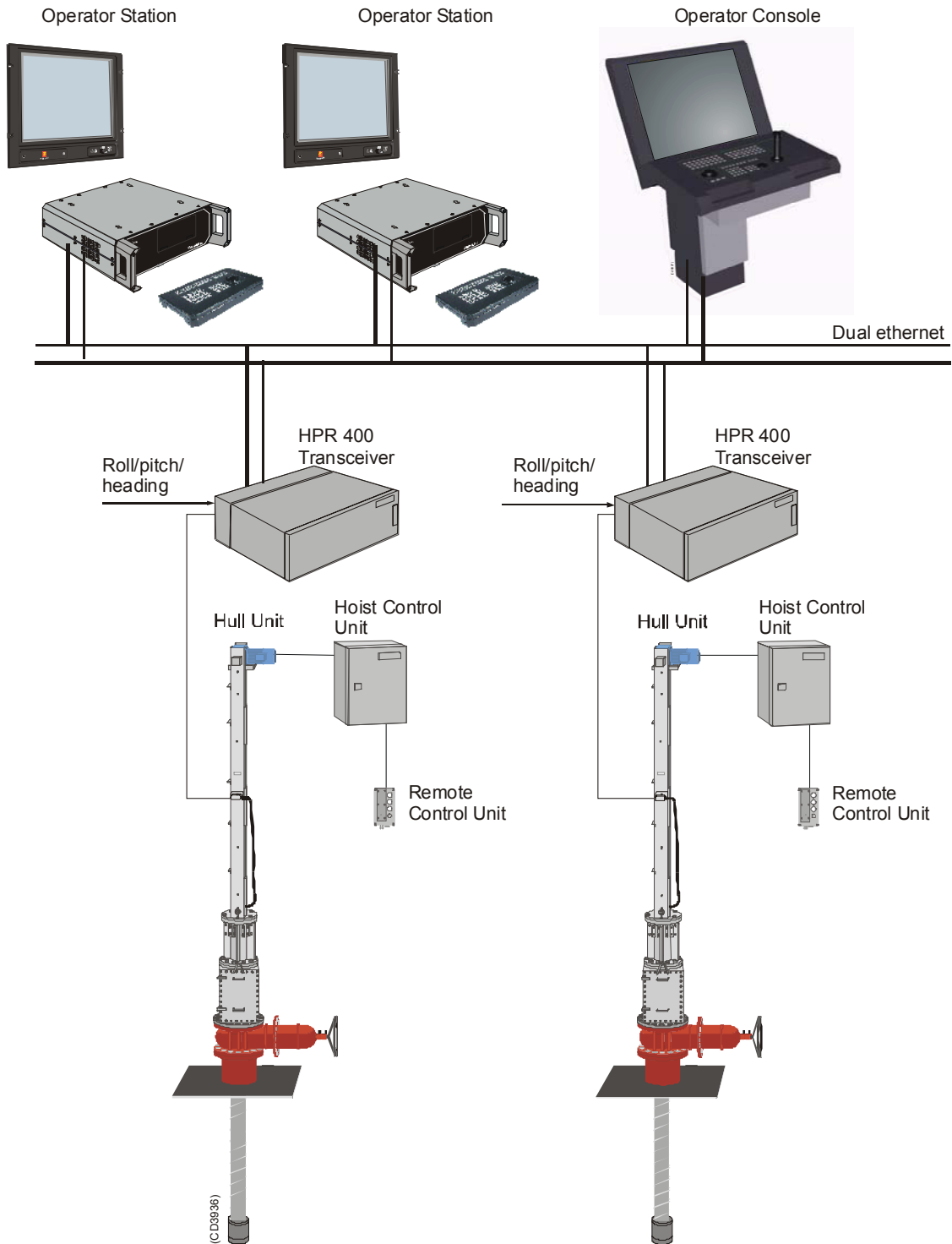

Transceivers

The system may be configured with from 1 to 4 transceivers. All transceivers are accessible from one operator station.

Transducers

The HPR 400 system may be configured with 2 SSBL-type transducers and 2 types of LBL transducers.

- **SSBL MEDIUM:** Standard MF SSBL transducer with 160/60° beam. The software algorithms keep narrow beam within 110°.
- **SSBL NARROW:** Narrow beam MF SSBL transducer with 160/30° beam. The software algorithms keep narrow beam within 45°.
- **SSBL 15 kHz:** Standard LF SSBL transducer with 160/60° beam. The software algorithms keep narrow beam within 110°.
- **LBL:** Simple transducer for LBL and telemetry, available with different beam patterns.
- **LBL 15 kHz:** Simple transducer for LBL and telemetry, available with different beam patterns.

TRANSPONDERS

General

The position calculation is based on range and/or direction measurements from the onboard transducer to the subsea transponder(s). The various transponder models have different depth rating, source level, lifetime, beam pattern and function.

The following transponder series are available:

- MPT - Multifunction Positioning Transponders
- SPT - SSBL Positioning Transponders
- MST - Mini SSBL Transponders

The MPT / SPT transponders are available with 1000 and 3000 m depth rating.

MPT transponders for 6000 m depth rating are also available.

The MST is available with 1000, 2000 and 4000 m depth rating.

The MPT and SPT transponders do all have acoustic telemetry included. By use of acoustic telemetry from the HPR system several parameters can be controlled:

- Read battery status
- Enable/disable
- Transmitter power
- Receiver sensitivity
- Change channel - frequency
- Read sensors, if any
- Acoustic release

For details, see the *Product Specification* for each of the models.

MPT series

The MPT series consists of a wide number of transponders all suited for SSBL and LBL use. Depth rating, beam pattern, release mechanism, pressure and temperature sensor are among the options/choices available.

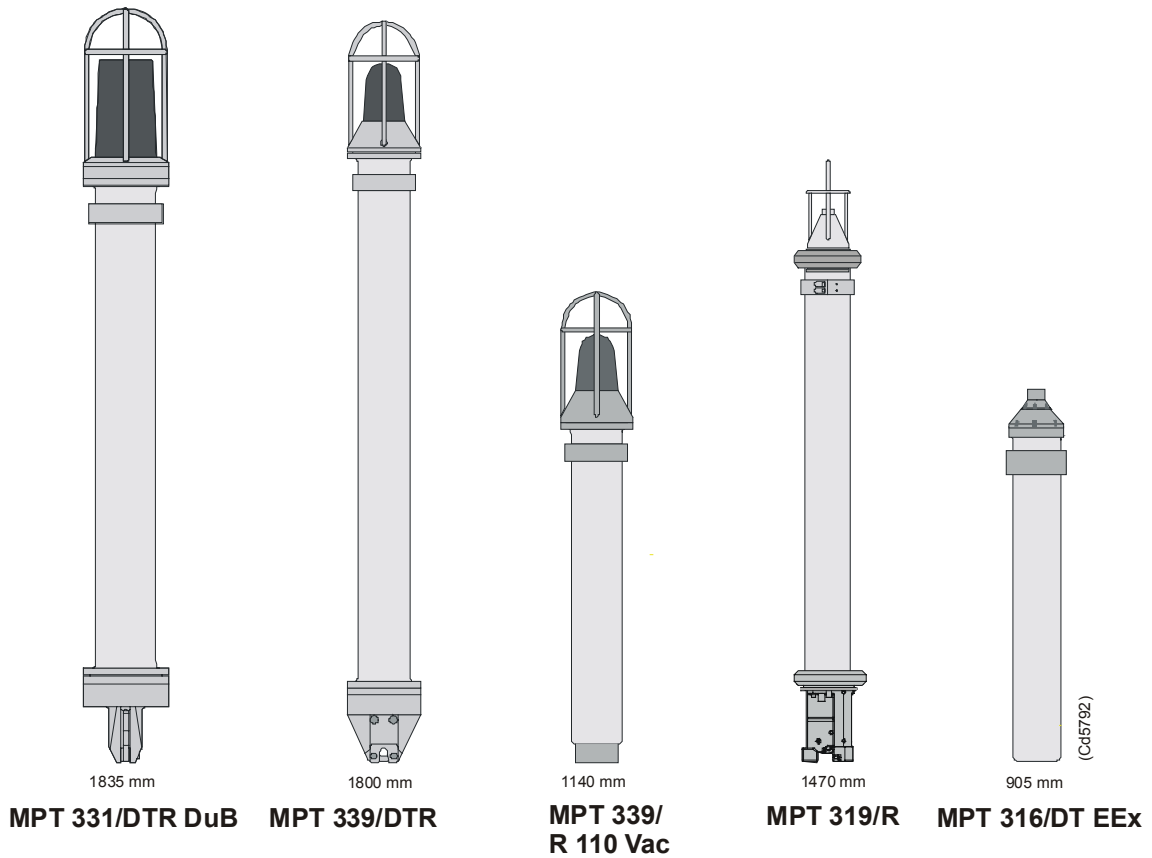

SPT series

The SPT series consists of a wide number of transponders. All suited for SSBL use. The SPT has the same hardware as the MPT, but only the SSBL functionality. Depth rating, beam pattern, release mechanism, inclinometers, pressure and temperature sensor are among the options/chooses available.

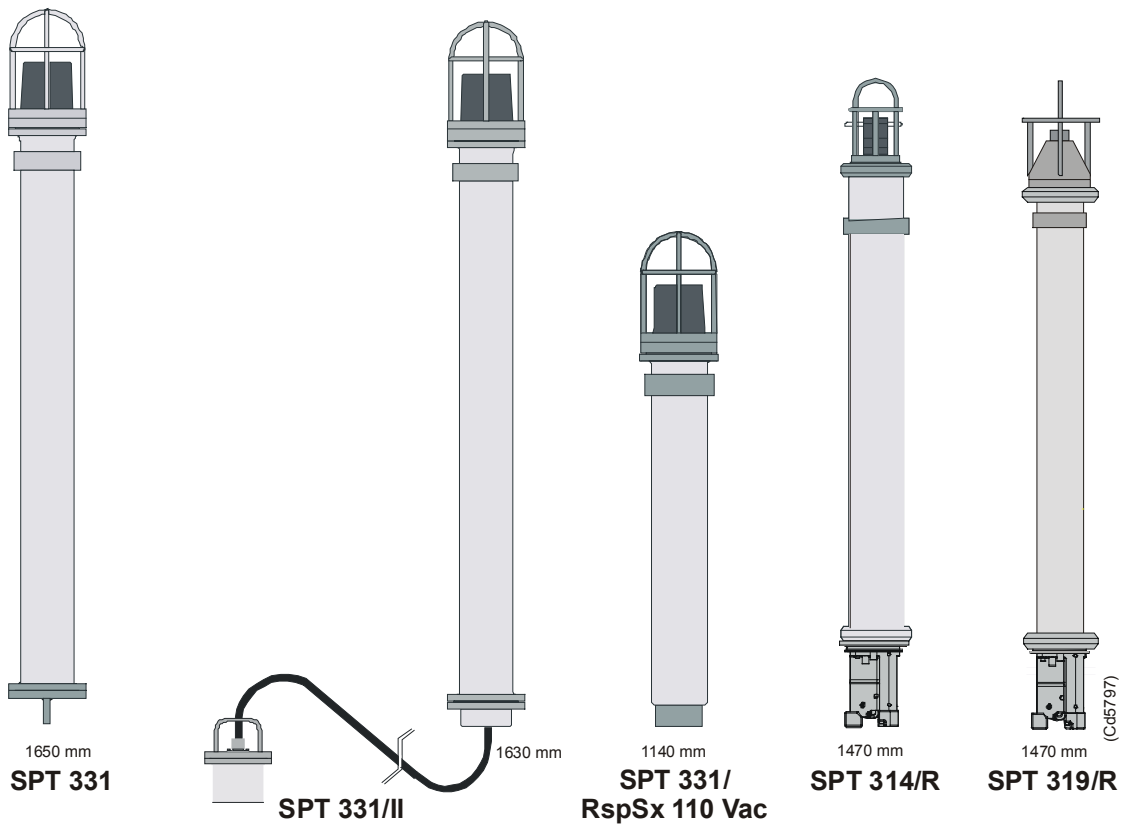

MST series

The MST is an SSBL mini transponder suited for ROV operation and where the size of the transponder can be a limiting factor. The transponder models cover various water depths. The MST series consists of the following models:

- MST 319 - rated for 1000 m water depth
- MST 324 - rated for 2000 m water depth
- MST 342 - rated for 4000 m water depth

All units have a rechargeable battery, can operate in responder mode and be externally powered.



(C:6424)

SYSTEM FUNCTIONS

Introduction

The HPR system consists of a wide range of functions. A function is selected by the operator. The basic systems have standard functions included, to ensure normal operation. The systems may be delivered with additional options selected from the system option list.

Main functions

General

The main functions in the HPR system are described below. The system may be configured with one or several of these functions. They will appear in the systems main menu.

List of main functions

The list below shows which functionality each of the functions includes. The "reg. no" is the unique identification for this function.

Example; the reg. no for APOS Base version is 886 - 212745.

Reg. no	Description
886-212745	<p>APOS base version</p> <p><i>APOS - Acoustic Position Operator Station</i></p> <p>Base for running all applications, includes:</p> <ul style="list-style-type: none"> • Sound velocity profile function • Ethernet interface for position data • Serial line, RS-422 for transceiver interface • Serial line, RS-422 for position data <p>Transponder telemetry for SPT / MPT transponders including:</p> <ul style="list-style-type: none"> • Set transmit power level • Set receive sensitivity • Set Pulse length • Change channel • Enable/Disable • Transponder release • Read battery status • Read sensor data, if any <p>Position and angle alarm:</p> <ul style="list-style-type: none"> • APOS software for HiPAP or HPR 400 providing alarm for transponder position and riser angle alarm. <p>APOS Depth sensor interface:</p> <ul style="list-style-type: none"> • APOS software for interfacing a depth sensor for depth compensation of position. Suitable for ROV or Tow fish positioning. <p>Interface to DGPS for providing data to transducer alignment:</p> <ul style="list-style-type: none"> • An SSBL transponder position can be presented in geographical coordinates. • The clock may be synchronised to 1PPS from the DGPS receiver.

Reg. no	Description
886-212747	<p>HPR 400 SSBL function</p> <p>APOS software for HPR 410 SSBL operation includes:</p> <ul style="list-style-type: none"> • Transponder positioning • Responder positioning • Use of MF or LF transducers • Interface for one synchro GYRO • Interface for one analogue VRU • Interface for one serial GYRO or attitude sensor • SSBL simulator for training <p>A responder controller pcb is required for responder use.</p>
886-212748	<p>LBL function</p> <p>APOS software for LBL operation using HiPAP or HPR 400 includes:</p> <ul style="list-style-type: none"> • Calibration of transponder array in local grid • Positioning of vessel/ROV in LBL array • Necessary transponder telemetry • LBL simulator for training • Geographical position output if tp origin are entered in geo coordinates <p>On HiPAP, it requires HiPAP SSBL function reg. no: 212746.</p> <p>Positioning of an ROV in LBL requires an HPR 400 Subsea Unit.</p>
886-212749	<p>HPR 410P SSBL function</p> <p>APOS software for HPR 410P SSBL operation includes:</p> <ul style="list-style-type: none"> • Transponder positioning • Responder positioning • Use of PMT 301 Transducer

Reg. no	Description
886-212750	<p>MULBL function</p> <p>APOS software for HiPAP and HPR 400 systems MULBL operation includes:</p> <ul style="list-style-type: none"> • Calibration of transponder array in local grid • Positioning of vessel in MULBL array • Necessary transponder telemetry <p>It requires HiPAP SSBL and LBL, reg. no.: 212746 and 12748.</p>
886-212751	<p>MULBL transponder array data</p> <p>APOS files containing transponder array data for MULBL.</p>
<p>ADDITIONAL OPTIONS</p>	
886-212752	<p>Beacon Mode</p> <p>APOS software for HiPAP or HPR 400 beacon and depth beacon operation.</p>
886-212753	<p>Inclinometer Mode</p> <p>APOS software for HiPAP or HPR 400 inclinometer transponder operation.</p>
886-212754	<p>Compass Transponder</p> <p>Mode APOS software for HiPAP or HPR 400 compass transponder operation.</p>
886-212755	<p>GEO LBL Calibration</p> <p>APOS software for HiPAP or HPR 400 for calibration of LBL array in geographical coordinates. In positioning mode the position may be reported in geographical coordinates.</p>
886-212757	<p>LBL Transponder Positioning Mode</p> <p>APOS software for HiPAP or HPR 400 for use of MPT transponders to be positioned in an LBL network. (old name was Tp Range Pos).</p>
886-212759	<p>APOS Master Slave function</p> <p>An extra copy of the functionality of the master operator station for installation on additional operator stations.</p> <p>The operator can select which station shall be the master. Can be used both for HiPAP and HPR 400 systems.</p>

Reg. no	Description
886-212760	<p>APOS Upgrade software Upgrade from HSC400 software to APOS software, including old functionality. This may require a new monitor and a APC 10 computer and keyboard.</p>
886-212761	<p>APOS External synch. APOS software for synchronising HiPAP or HPR 400 transceivers to external equipment.</p>
886-212762	<p>APOS DUAL Ethernet APOS software and hardware for use of SDP dual Ethernet. Requires one Ethernet.</p>
886-212764	<p>HPR Transceiver DUAL Ethernet An SDN 400 module mounted in HPR transceiver cabinet for interface to dual Ethernet.</p>
886-212765	<p>APOS ACS BOP function APOS software for telemetry to ACS 400 or ACS 300 system used on BOP. Telemetry to ACS 300 only available on HPR 400 systems.</p>
886-212766	<p>APOS ACS OLS function APOS software for telemetry to ACS 300 system used on OLS. Telemetry to ACS 300 only available on HPR 400 systems.</p>
886-212767	<p>APOS STL function APOS software for HiPAP or HPR 400 systems for STL fields special functions including:</p> <ul style="list-style-type: none"> • Scanning of MLBE depth and position • Positioning of STL buoy • Scanning of transponder battery status • Graphics showing STL connection point
886-215836	<p>APOS Anchor Line Monitoring function APOS software for HiPAP and HPR 400 systems. Scanning of up to 9 transponder(s) installed on Anchor Lines/Anchor Line Buoys, presenting individual:</p> <ul style="list-style-type: none"> • Depth • Position • Scanning of transponder battery status

Reg. no	Description
886-215837	<p>HiPAP Transponder Relay Function</p> <p>Enables use of relay-function, relay-transponder frequency allocation, operator interfaces and displays functionality.</p>
886-215939	<p>SAL Tension & Yoke monitoring</p> <p>APOS software HiPAP or HPR 400 systems for showing Tension and Yoke including:</p> <ul style="list-style-type: none"> • Graphical presentation of yoke-angle • Graphical presentation of tension • Table for converting inclination angle to tension
886-212768	<p>APOS Field transponder array data</p> <p>APOS files containing transponder array data for offshore loading fields.</p>
886-212769	<p>APOS Training version</p> <p>A CD containing the APOS software and a copy of the APOS manual. This is suitable for demonstrations and training purposes. The APOS can be operated as normal and a simulator replaces transceiver and transponders. It can also be used to check telegram interfaces.</p> <p>This requires a computer with CD-ROM player, running NT40, and a monitor with 1024 x 768 resolution.</p>

TECHNICAL SPECIFICATIONS

SSBL Accuracy

HPR 400 Standard transducer 20-32 kHz

Wide beam $\pm 80^\circ$	≤ 5 % of slant range
Narrow beam $\pm 55^\circ$	≤ 2 % of slant range

HPR 400 Narrow beam transducer 20-32 kHz

Wide beam $\pm 80^\circ$	≤ 5 % of slant range
Narrow beam $\pm 22.5^\circ$	≤ 1 % of slant range

HPR 400 Standard transducer 10-15 kHz

Wide beam $\pm 80^\circ$	≤ 5 % of slant range
Medium beam $\pm 55^\circ$	≤ 2 % of slant range

Note !*The specification is based on:*

- Line of sight from transducer to transponder
- No influence from ray bending
- Signal to Noise ratio ≥ 20 dB. rel. $1\mu\text{Pa}$
- No error from heading and roll/pitch sensors

LBL accuracy

The position accuracy for LBL operation is very dependent on the transponder array geometry, sound velocity errors and signal to noise ratio. However, simulations can show the accuracy.

The following “one sigma” error contribution to the range measurements are assumed (20-30kHz system):

- Range reception with 20dB S/N: 0.15 meter
- Range reception in the transponder: 0.15 meter
- Range error due to T_p movement: 0.10 meter
- Range error due to rig movement: 0.20 meter

The random errors are added as Gaussian noise to the measurements.

The figure shows the error in the horizontal position when the Rig moves within the transponder array. The simulations are done with 4 LBL transponders placed on the Seabed in a circle with radius 636m. The water depth is 1200 m. The error is showed as a function of the East coordinate. The north coordiante is zero, and the East coordinate zero is consequently the centre of the array. We have assumed that the wide beam of the Rig transducer is used, and that the S/N when receiving the transponder replies is 20 dB. The effect of a systematic error in the Sound velocity of 1 m/s is also showed. When being in the centre of the array, that error causes no position error. When being in the outer parts of the array, that error causes a significant systematic error in the position.

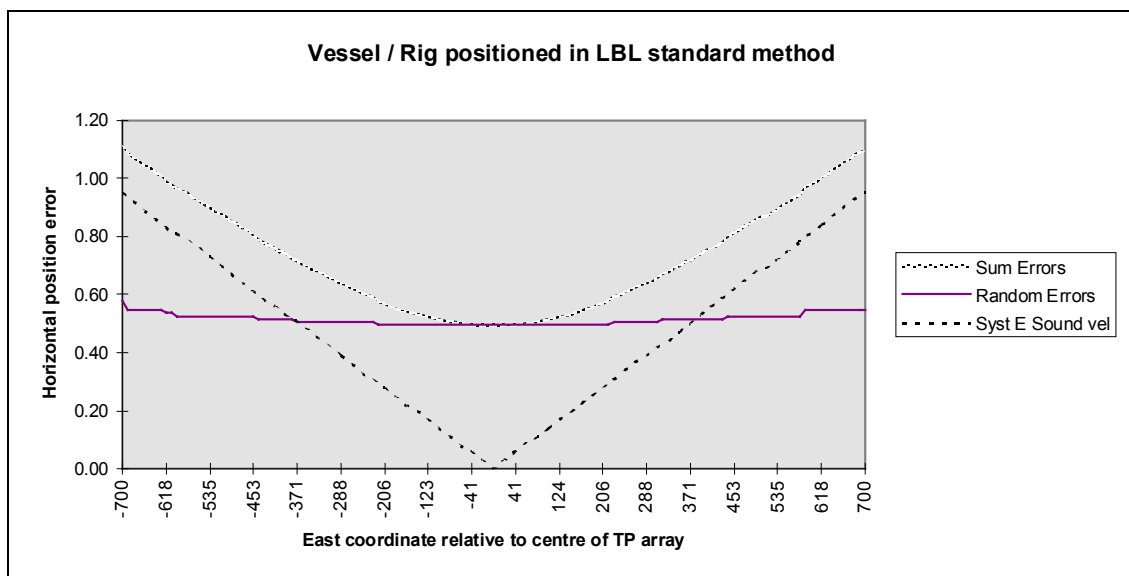

Range capabilities

The range capabilities depend on the vessels noise level, transponder signal level and transponder type. Ray-bending effects may also reduce the operating range. The figures are based on 20-32 kHz systems and are approximate values for guidance.

Standard transponder:

w/ 188 dB rel.1µPa ref.1m..... Typical 1000 m - 1500 m

High power transponder:

w/ 195 dB rel.1µPa ref.1m..... Typical 1500 m - 2000 m

High power transponder:

w/ 206 dB rel.1µPa ref.1m..... Typical 2500 m - 4000 m

Note !

The specification is based on:

- Line of sight from transducer to transponder
- No influence from ray bending
- Signal to Noise ratio ≥ 20 dB. rel. $1\mu\text{Pa}$
- No error from heading and roll/pitch sensors

Unit specifications

APC 10 computer

General:

Unit for desktop installation	17 kg
Unit for rack installation (including rails and side plates)	17 kg
Colour graphics resolution	Eligible max. 1600 x 1200
Video output	15 pin, analogue VGA
Floppy drive	3.5"
Printer interface	parallel
Electrical interfaces	RS-422, RS-232, Ethernet

Power supply:

Voltage	180-264 Vac/ 90-132 Vac
Frequency	50-60 Hz
Max Inrush current	80 A
Nominal	80 W

Temperature:

Storage	-40° C to +70° C
Operating	+10° C to +55° C

Humidity:

Storage / operating	85% / 95% relative
---------------------	--------------------

Vibration:

Range	5-100 Hz
Excitation level	5-13.2 Hz ± 1.5 mm, 13.2-100 Hz 1 g

Telegram formats:

Serial lines	Ethernet
- Binary HPR 209/309	- Binary HPR 400
- Binary HPR 400- BCD code	- Proprietary NMEA
- Proprietary NMEA	

WinKeyboard

Weight	3 kg
Cable length	2 m

Display 17.4" TFT

Humidity operating	30 - 90% relative
Operating temperature	-15° C to +55° C
Humidity storage	10 - 90% relative
Storage temperature	-20° C to +60° C
Vertical frequency range	60 - 85 Hz
Horizontal frequency range	31.5 – 91.1 kHz
Supply current	0.7 - 1.7 A
Resolution	640 x 350 pixels (min) 1280 x 1024 pixels (max)
Weight	9.2 kg (w/bracket)
Dimensions (W x H x D)	(460 x 400 x 60.10) mm

Power supply display:

Supply voltage	24 Vdc
----------------	--------

Power supply unit:

Input voltage	115 / 220 Vac
---------------	---------------

HPR 400 transceiver unit

Power supply, voltage	185 – 264 Vac
Power supply, frequency	50-60 Hz
Power supply, consumption max.	55 W
Temperature, storage	-20 to +60° C
Temperature, operating	0 to +55° C
Degree of protection, in 6u cabinet	IP 54
Humidity, storage / operating	90% / 80% relative

Heading reference:

- Synchronous
- Serial RS 422 SKR format
- Serial RS 422 STL format
- Serial RS 422 NMEA format
- Serial RS 422 Seatex MRU or Seapath
- Serial RS 422 DGR format (Tokimec DGR 11)

Roll and pitch reference:

- Analogue Sine $\pm 90^\circ \pm 10$ V
- Analogue Sine $\pm 15^\circ \pm 10$ V
- Analogue linear $\pm 60^\circ \pm 10$ V
- Analogue Seatex MRU $\pm 20^\circ \pm 10$ V
- Serial RS 422 Seatex MRU or Seapath

Transducer frequency combinations:

- 2 SSBL MF and 2 LBL/Telemetry MF
- 2 SSBL LF and 2 LBL/Telemetry LF
- 1 SSBL & 1 LBL/Telemetry MF and 1 SSBL & 1 LBL/Telemetry LF

Transponders in use	max. 56
Transponder channels	HPR 300 and HPR 400

Hoist control unit

Power supply:

Voltage	230 / 440 Vac 3 Phase
Frequency	50-60 Hz
Consumption max.	1100 W

Temperature:

Storage	-20° C to +60° C
Operating	0° C to +55° C

Humidity:

Storage / operating	80% / 90% relative
---------------------	--------------------

Protection:

Degree of protection	IP 54
----------------------	-------

Weight	12 kg
--------	-------

Remote control unit

Power supply:

The Remote Control Unit is supplied with 24 Vdc from the Hoist Control Unit.

Voltage	240 Vdc
Frequency	50-60 Hz
Consumption	6 W

Temperature:

Storage	-20° C to +60° C
Operating	0° C to +55° C

Humidity:

Storage	10 - 90% relative
Operational	30 - 80% relative

Protection:

Degree of protection	IP 54
----------------------	-------

Weight	1.5 kg
--------	--------

Flange

Certificates

Lloyd's and DNV certifications are standard, others on request.

Dimensions

Standard height	600 mm
Optional height	Specified by customer
Diameter: Internal / Flange	500 mm / 670 mm
Wall thickness	20 mm
Weight, standard	90 Kg

Gate valve

Certificates

Lloyd's and DNV certifications are standard, others on request.

Dimensions

Type	DN500
Height	350 mm
Length (from centre)	1335 mm
Diameter: Internal / Flange	500 mm / 670 mm
Weight	510 Kg

Hull units

Power supply, voltage	230 / 440 Vac 3 Phase
Power supply, frequency	50-60 Hz
Power supply, consumption max.	1100 W
Temperature, storage	-20° C to +60° C
Temperature, operating	0 ° C to +55° C
Degree of protection	IP 54
Humidity, storage / operating	90% / 80% relative

Weight:

HL3880	1225 Kg
HL3100	1261 Kg
HL2300	1161 Kg
HL1530	1061 Kg
HL 3380 Ex-1	1336 Kg

Outline dimensions

The outline dimensions shown in this section are for information only and must not be used for installation or manufactory purposes. For exact information, please use the installation manuals.

APC 10 computer

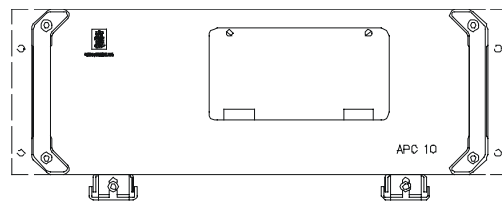

All measurements in mm.

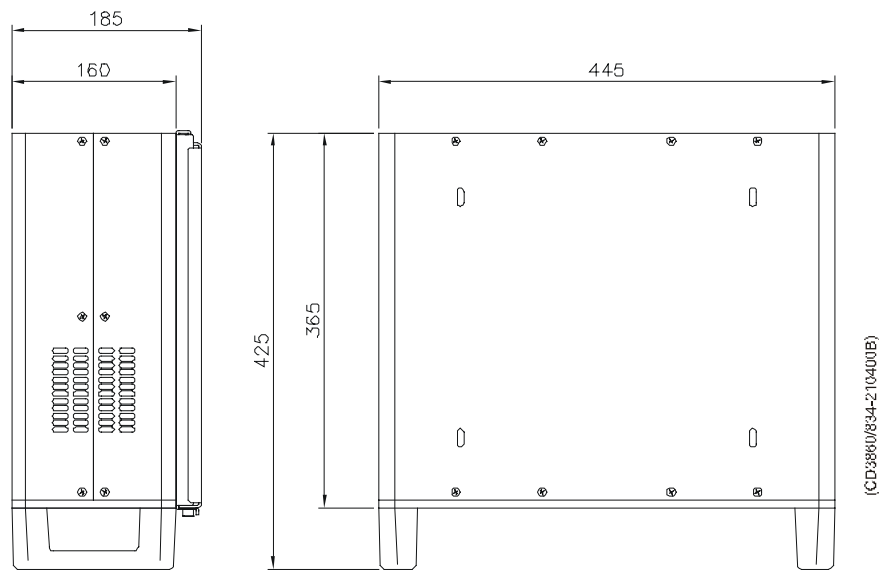

WinKeyboard

(CD3861/210401A)

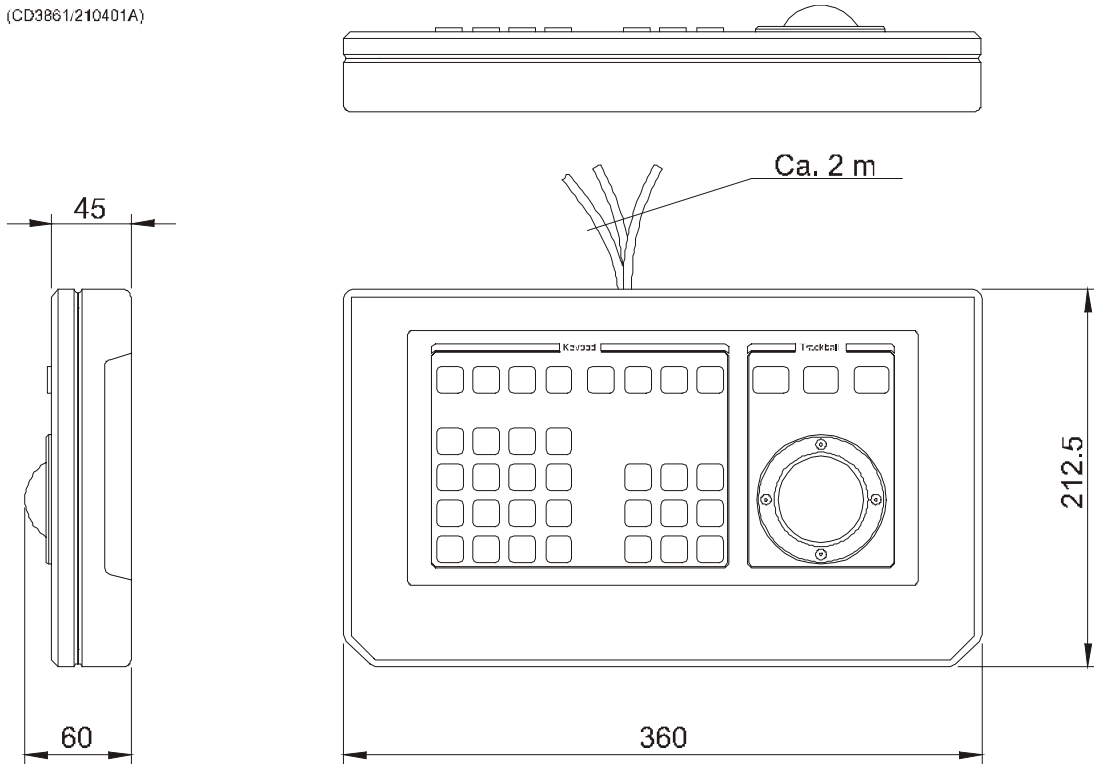

17.4" TFT display

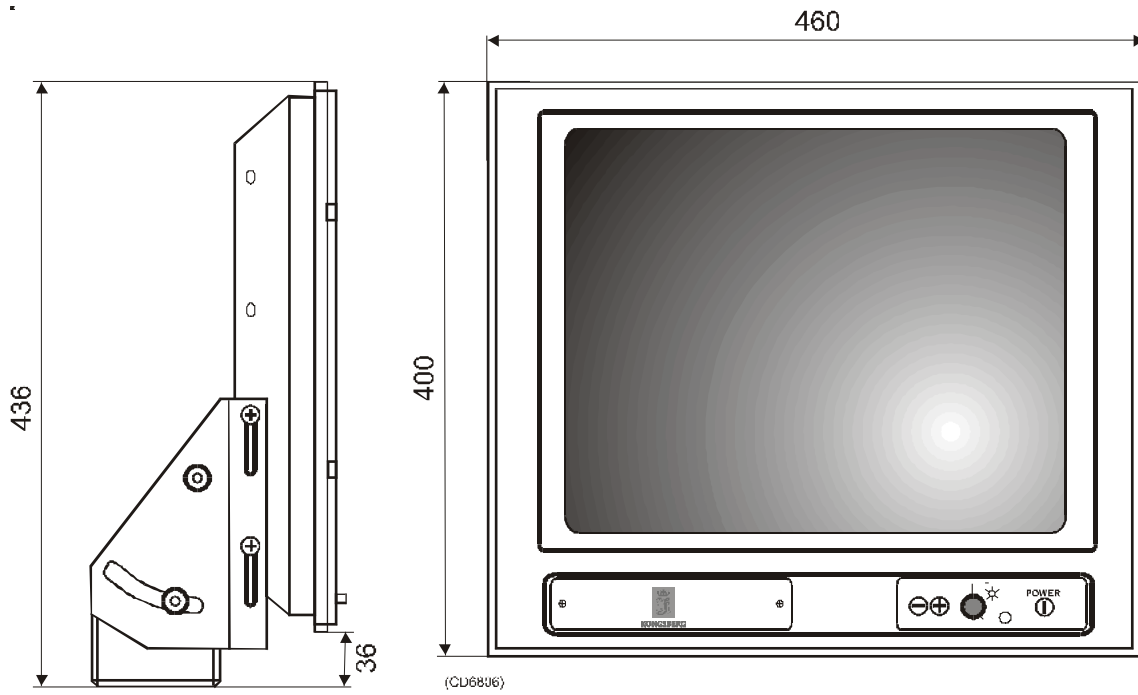

Operator console



HPR 400 transceiver – 19" rack

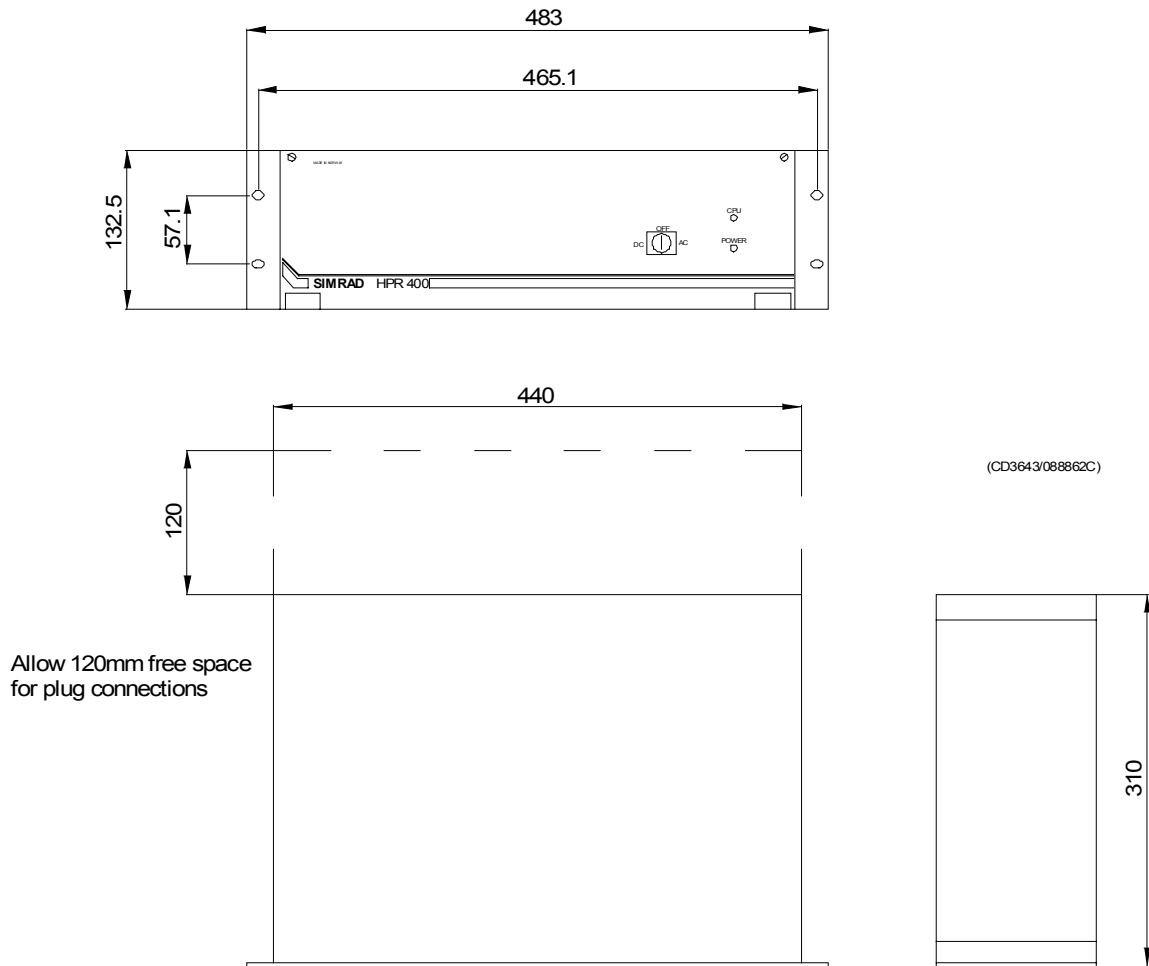

HPR 400 transceiver – 6u cabinet

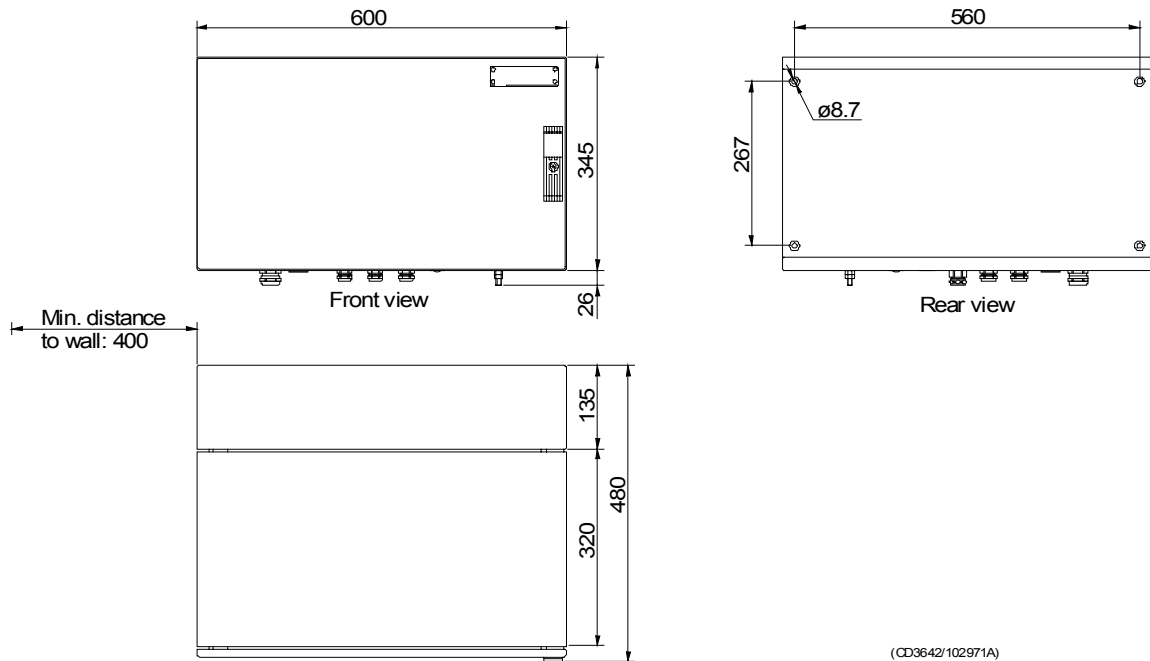

HL3880 / HL3100 / HL2300 / HL1530

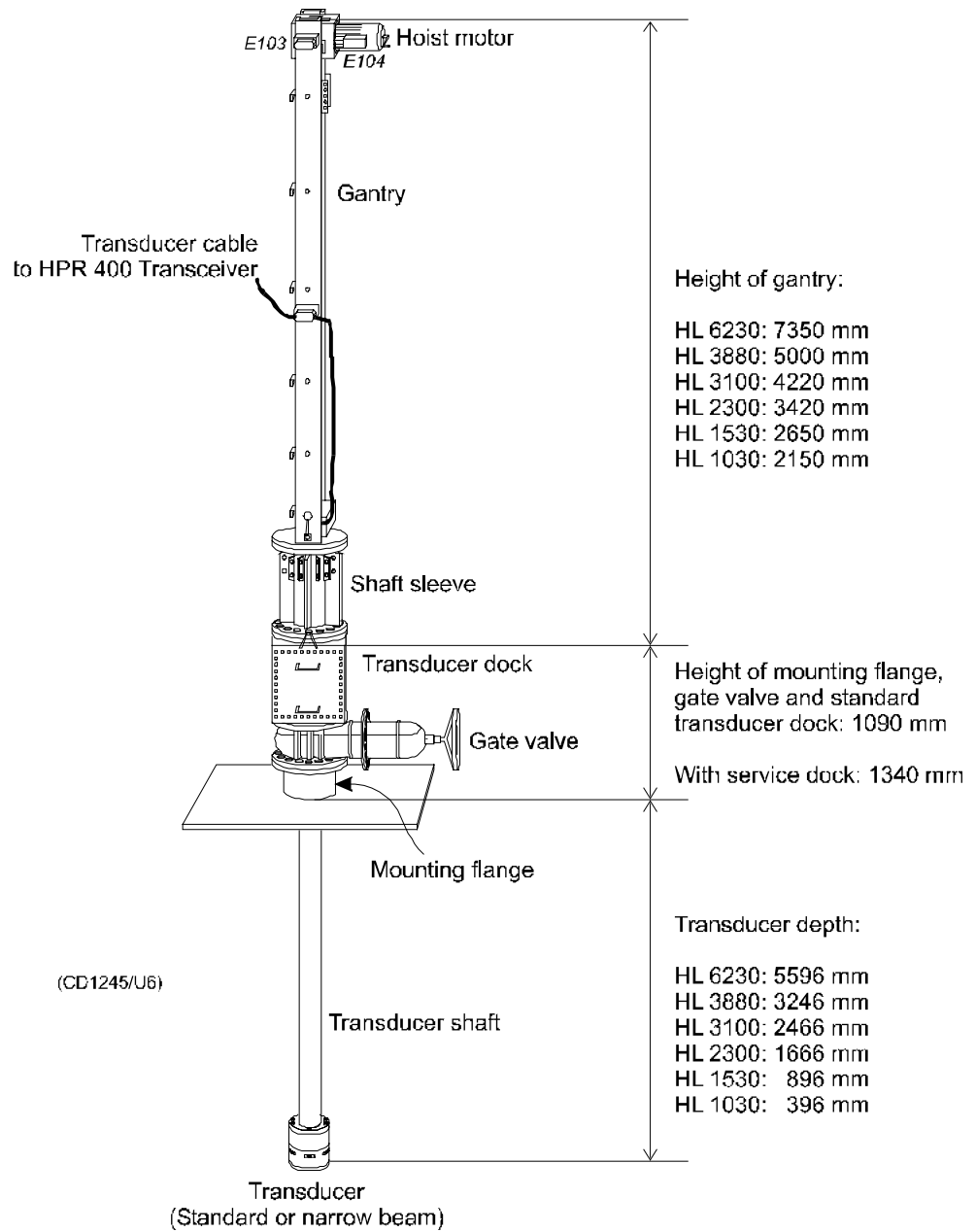

Hoist control unit

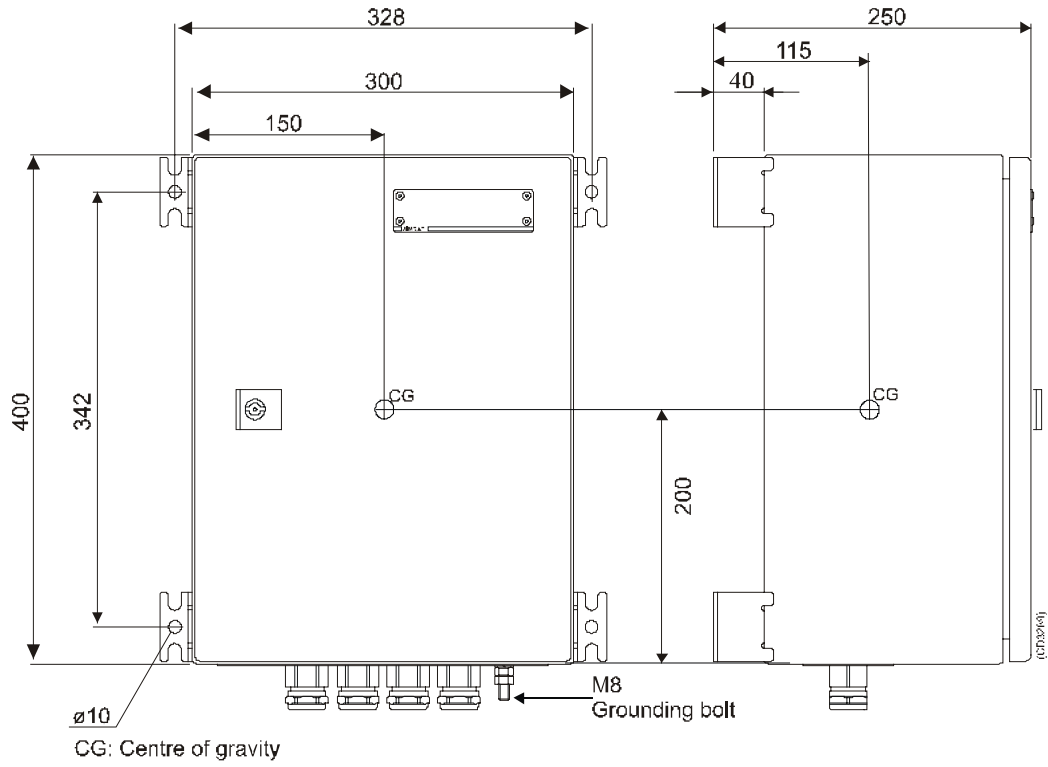

Remote control unit

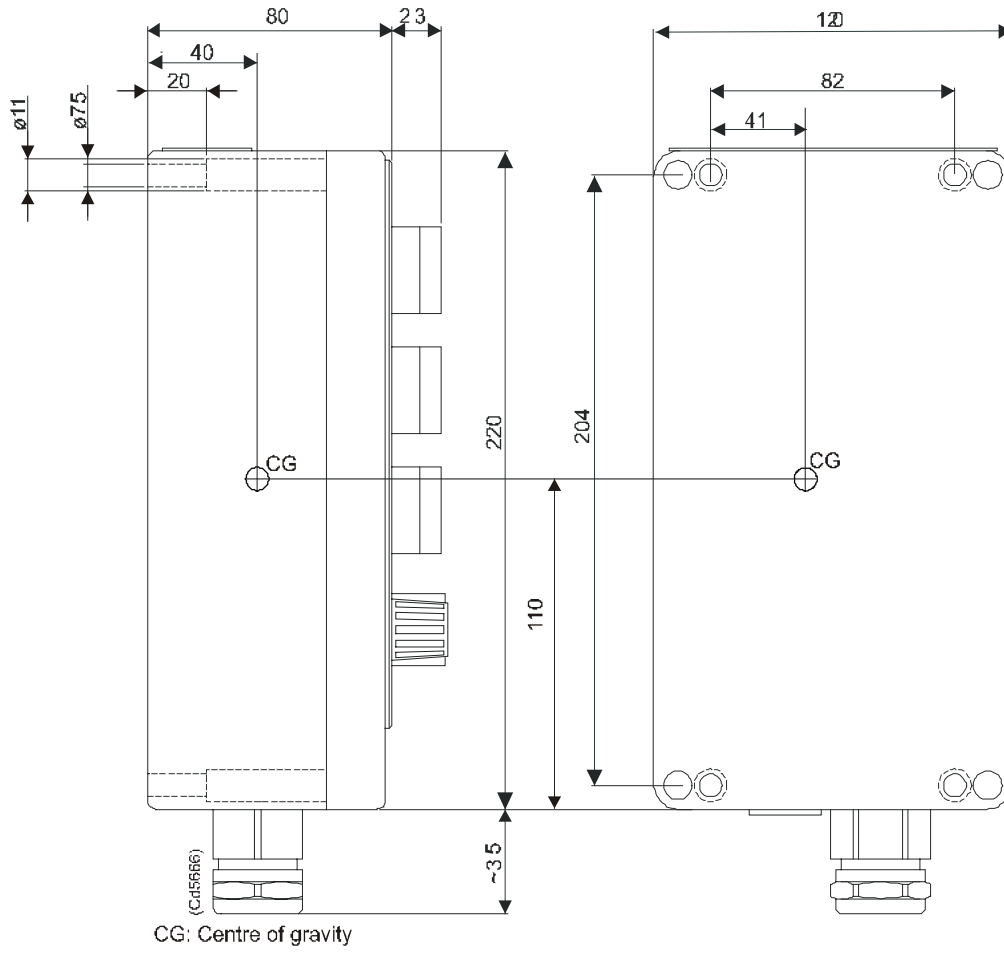

HL 3380 Ex - 1

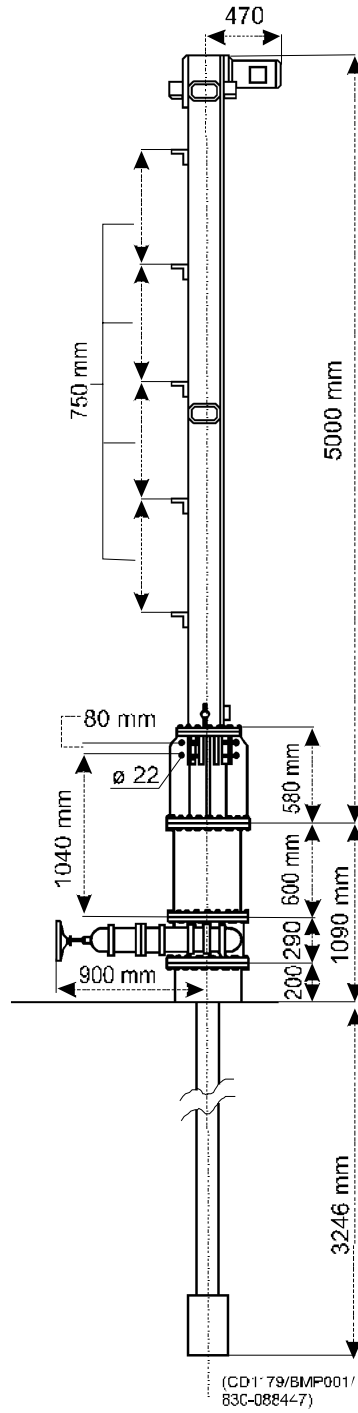

Relay unit Ex - 1

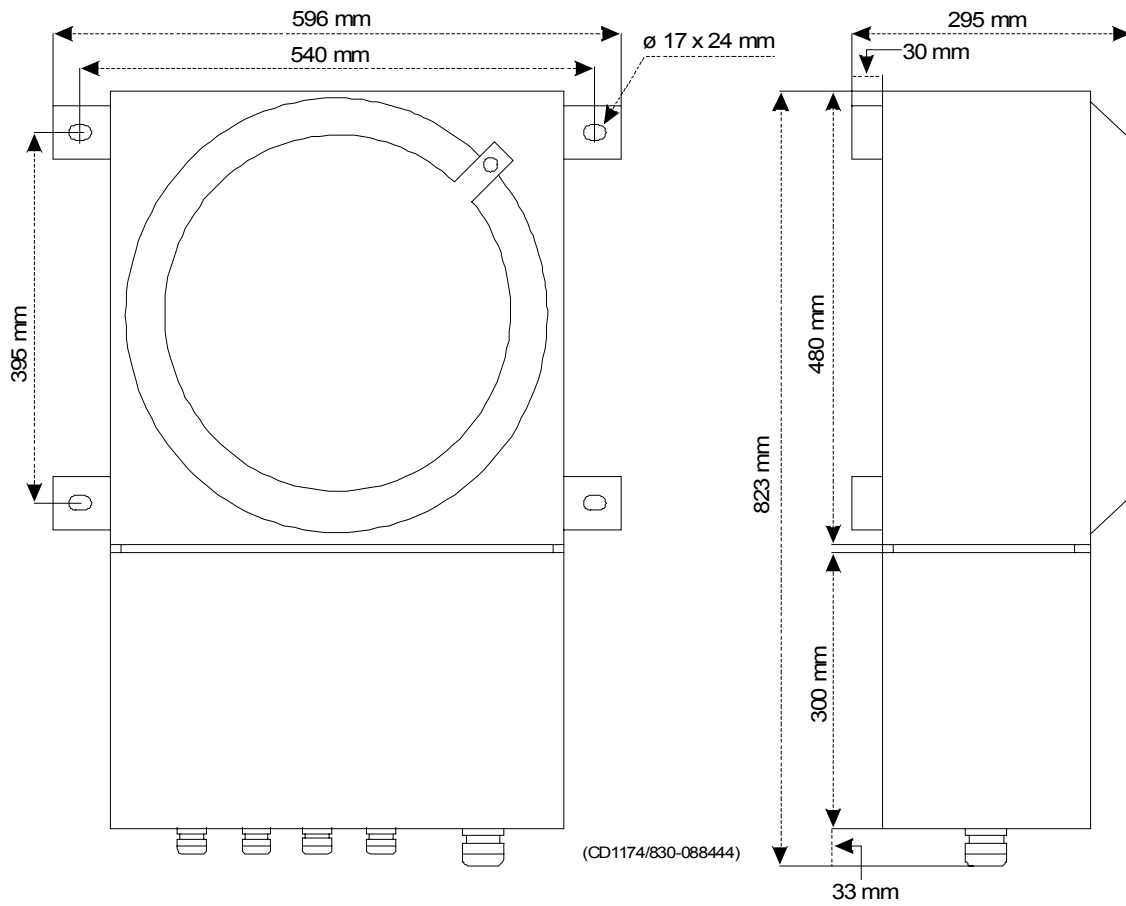

Local control unit Ex – 1

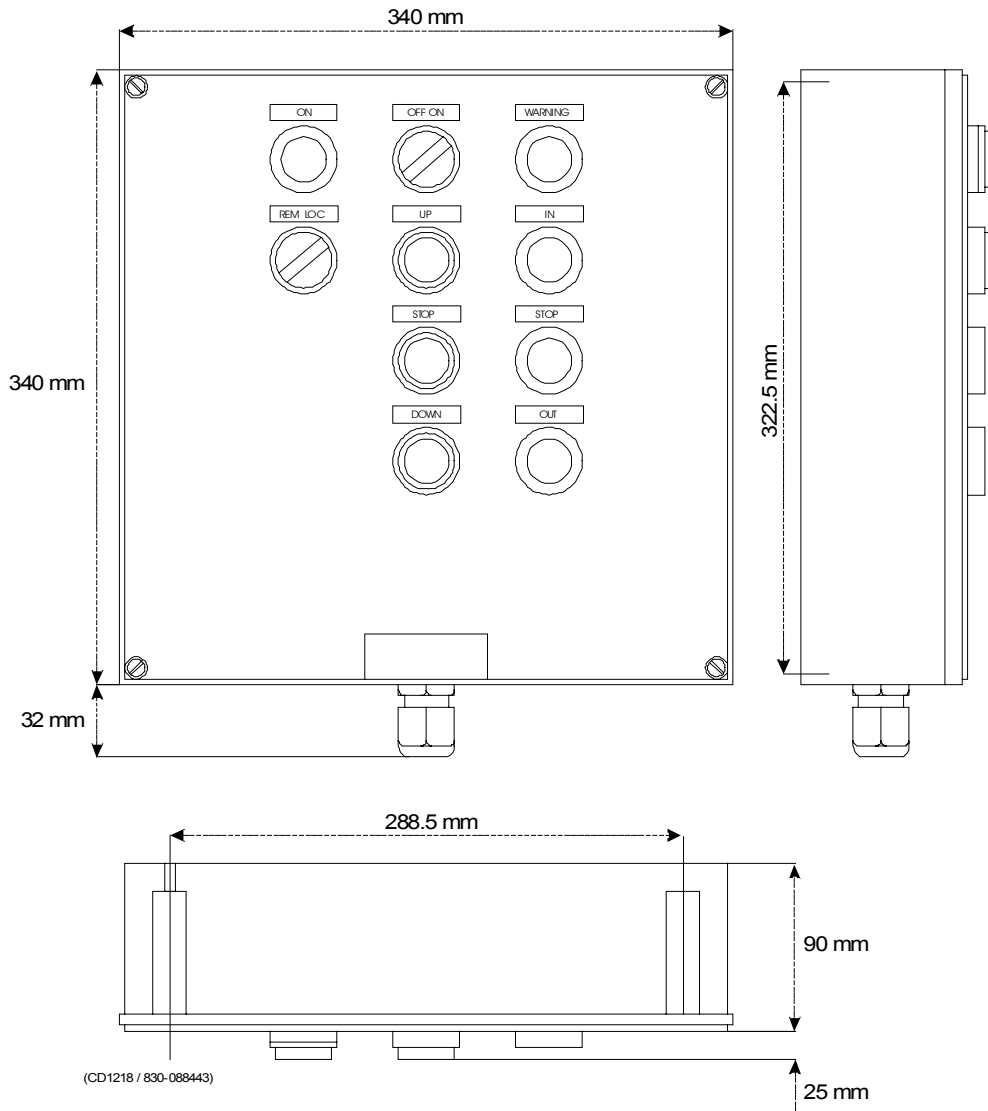

Remote control unit Ex – 1

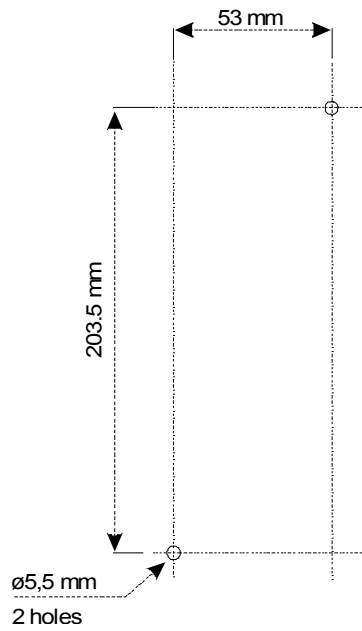
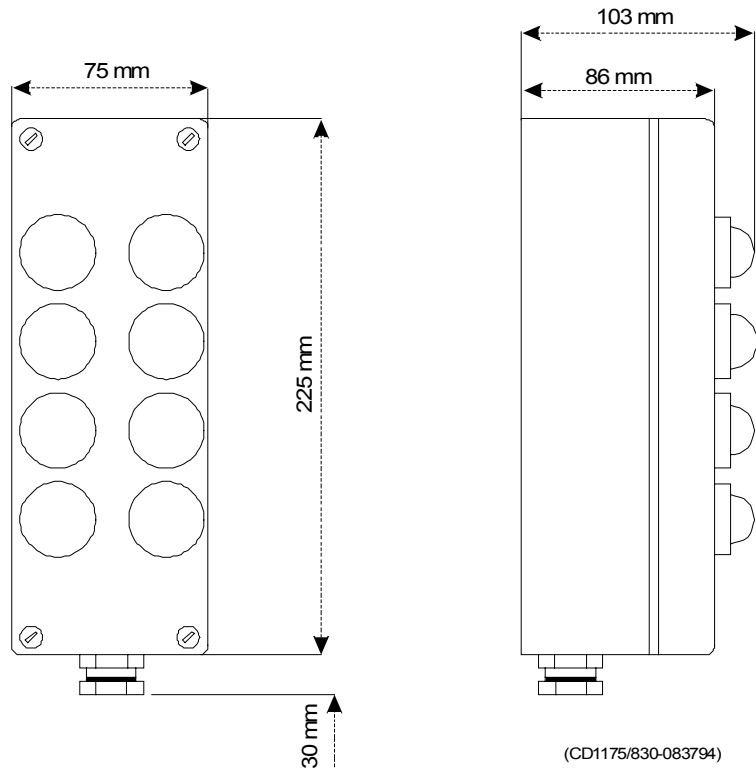

Standard transducer

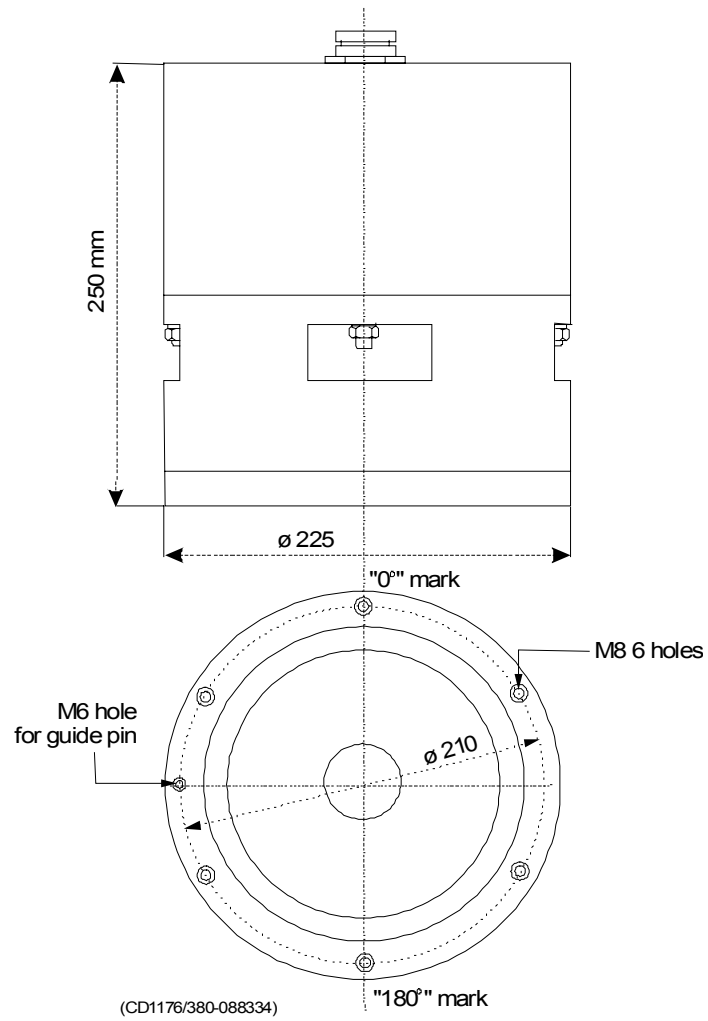

Narrow /LF Medium beam transducer

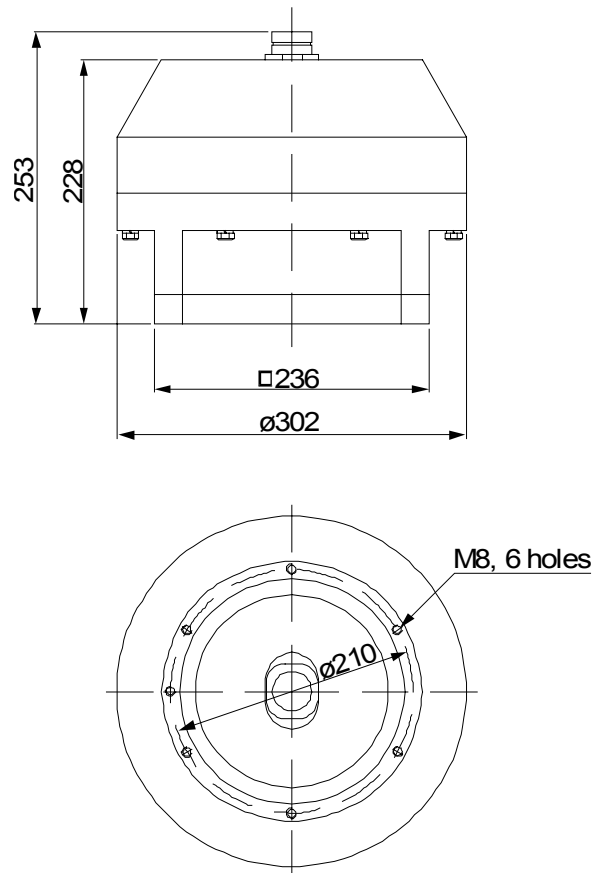

(CD1177/830-082498)

Gate valve and flange – 500 mm

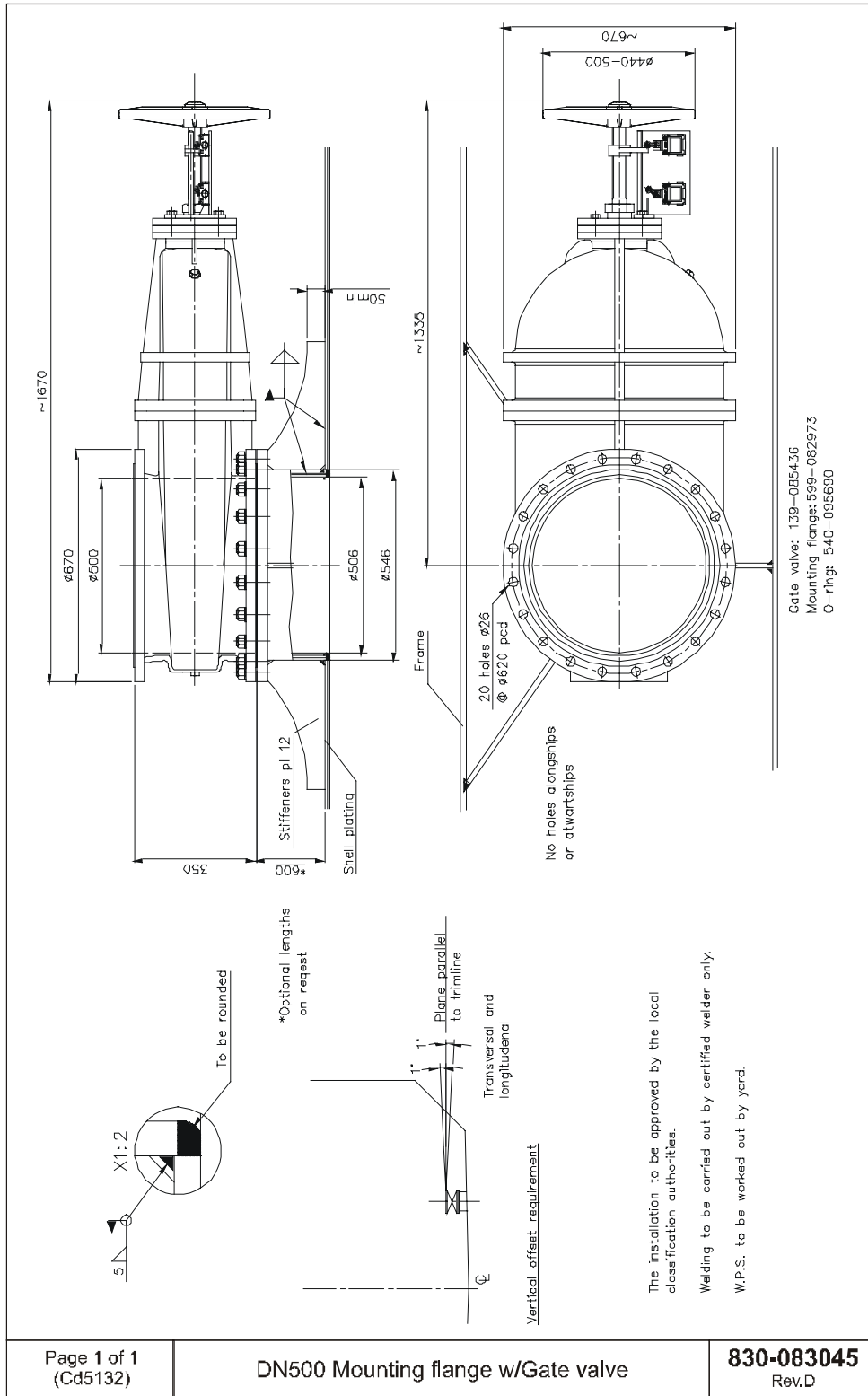

Gate valve and flange – 350 mm

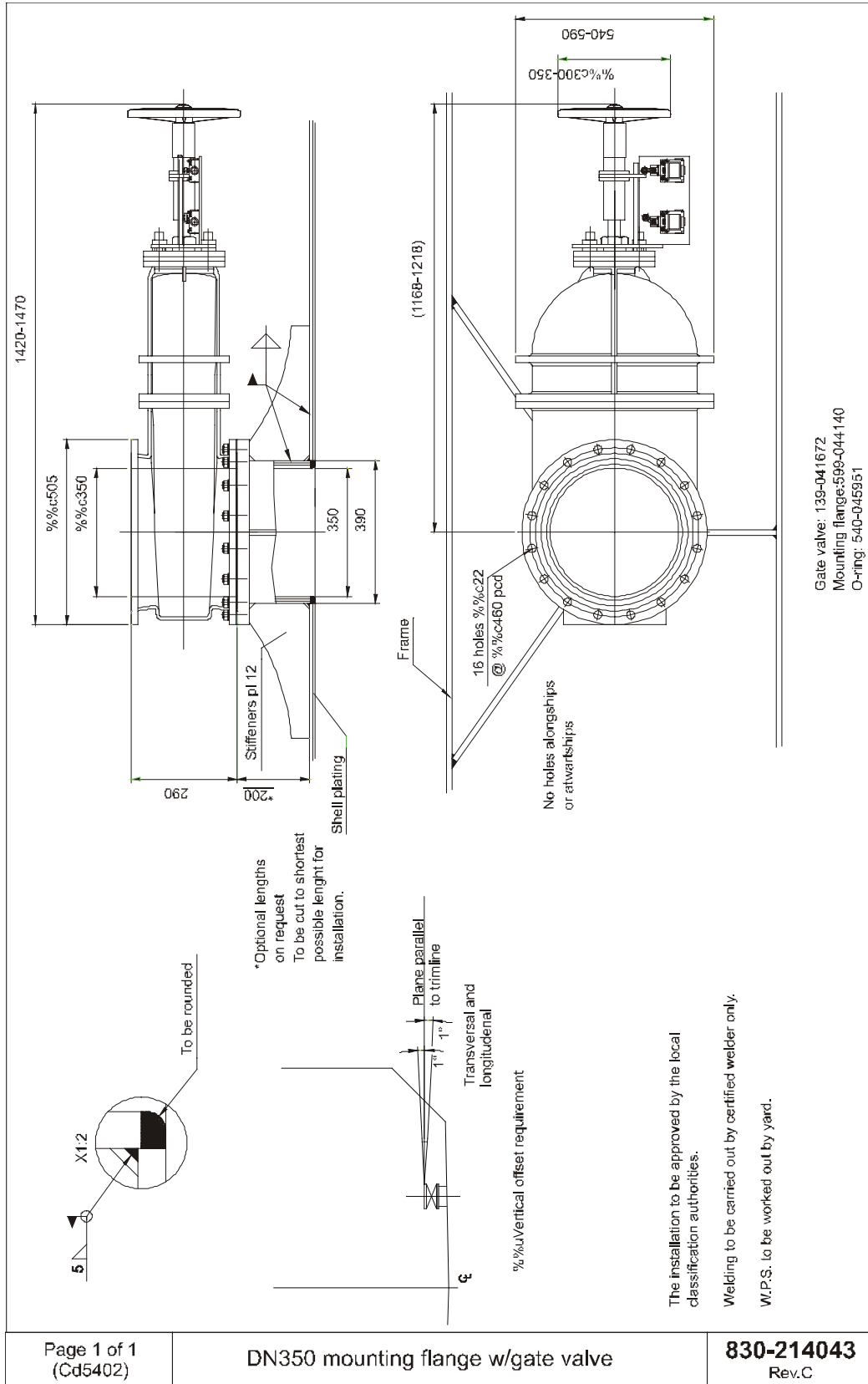

857-201392 / AA000/6-12

Attitude formats description

This document describes the gyro and vru formats the HiPAP and HPR 400 Series can receive.

Document revisions

Rev	Documentation Department		Hardware/Software design		Project/Product Management	
	Date	Sign	Date	Sign	Date	Sign
A			08.08.97	OB		
B	27.02.98	GM	27.02.98	OB	27.02.98	JEF
C	02.05.01	GM	02.05.01	THG	02.05.01	JEF
D						

(The original signatures are recorded in the company's logistic database)

Contents

1	INTRODUCTION	5
	Abbreviations	5
2	GYRO FORMATS	6
	SKR serial line format.....	6
	STL serial line format	7
	DGR serial line format	8
	NMEA serial line format.....	9
	MRU serial line format.....	10
	Seapath serial line format	10
	Synchro.....	11
	Sin Cosin	11
	4-20 mA	11
	Sync spare	11
3	VRU FORMATS	12
	NMEA serial line format.....	12
	MRU serial line format.....	12
	Seapath serial line format	12
	Piro40 90°	12
	Piro40 15°	12
	Sync spare	12
	Sperry analogue	13
	Schaevitz	13
	MRU 20° 10v.....	13
	Vru 200A	13

Document history

(The information on this page is for internal use)

- Rev. A** Original issue.
- Rev. B** Document updated to correct minor errors. Ref. EM 857-201392B.
- Rev. C** Removed DGR format for HiPAP. Corrections in the MRU serial line format. New layout. Ref. EM 857-201392C.

1 INTRODUCTION

This note is a technical documentation that may be changed. The connections between HPR and gyro's or vru's are not described here.

- HiPAP can receive the serial line formats, i.e. SKR, STL, NMEA, MRU and SEAPATH.
- HPR 400 can use all formats.

The note is divided in chapters like the install gyro and vru menu in the HSC.

Abbreviations

HPR	Hydroacoustic Positioning Reference system
HiPAP	High Precision Acoustic Position system
HSC	HPR system controller, the operator unit
rms	Root mean square
bps	Baud per second
ms	Millisecond
deg	Degrees
rad	Radians
m	Meter

2 GYRO FORMATS

SKR serial line format

Robertson SKR80/82 serial line format.

Interface format: RS-422.

9600 bps, 8 data bits, 1 stop bit, odd parity.
< 150 ms between each telegram.

Telegram format: 4 bytes, LSD first and MSD last.

Bit	Description	Values
7 - 6	Not used	0 (ignored)
5 - 4	Address	0 = tenths 1 = units 2 = tens 3 = hundreds
3 - 0	Data	0 - 9, BCD-code

Example: Course: 234.5 deg.
Telegram: 05 14 23 32

STL serial line format

STL serial line format.

Interface format: RS-422.

9600 bps, 8 data bits, 1 stop bit, no parity.
< 5 seconds between each telegram.

Telegram format:

Telegram consists of 7, 8 or 13 ascii-coded bytes, starting with STX and ending with ETX, COMMA or CR. The 7 and 8 byte telegram contains course information, and the 13 byte telegram contains course and ships speed information. The speed is ignored.

Byte			Description	Values
1	1	1	STX	02h
	2	2	K (course)	4Bh
2	3	3	hundreds	30h-33h
3	4	4	tens	30h-39h
4	5	5	units	30h-39h
5	6	6	POINT	2Eh
6	7	7	tenths	30h-39h
		8	L (speed)	4Ch
		9	tens	30h-39h
		10	units	30h-39h
		11	POINT	2Eh
		12	tenths	30h-39h
7	8	13	ETX, COMMA or CR	03h, 2Ch or 0Dh

Examples: Course: 234.5 deg.

7 byte telegram: 02 32 33 34 2E 35 03

8 byte telegram: 02 4B 32 33 34 2E 35 2C

13 byte telegram: 02 4B 32 33 34 2E 35 4C 31 32 2E 33 0D

DGR serial line format

DGR serial line format.

Interface format: RS422.

9600 bps, 7 data bits, 2 stop bit, no parity.

Any length between each telegram.

Telegram format: Telegram consists of 6 ascii-coded bytes.

Byte	Description	Values
1	Hundreds	30h-33h
2	Tens	30h-39h
3	Units	30h-39h
4	Tenths	31h-36h 31h: 0 deg. 32h: 2/6 deg. ~ 0.3 33h: 1/6 deg. ~ 0.2 34h: 4/6 deg. ~ 0.7 35h: 5/6 deg. ~ 0.8 36h: 3/6 deg. = 0.5
5	Anything	Ignored
6	LF	0Ah

Example: Course: 234.5 deg.

Telegram: 32 33 34 36 0D 0A

NMEA serial line format

NMEA serial line format.

Interface format: RS-422.

2400-9600 bps auto detect,

8 data bits, 1 stop bit, no parity.

< 5 seconds between each telegram.

Telegram format: Contains ascii characters.

*\$ address ,data, ... ,data *checksum "CRLF"*

These sentence formatters are decoded.

Approved: HDT, VHW.

Special: HRC (Yokogawa).

Proprietary: SXN (Seatex Norway).

Seatex proprietary MRU NMEA telegram:

*\$SPSXN ,id ,token ,roll ,pitch , , , , *checksum "CRLF"*

Id: 10 or 11. 10 if valid data, 11 if invalid data.

Token: Not decoded.

Roll/pitch: Scientific float data, i.e. 1.23e-1. [rad]

Example: *\$SPSXN,10,014,-9.100e-3,-1.823e-2,,,,,*20"CRLF"*

MRU serial line format

Seatex Simrad EM1000 and EM3000 serial line format. EM1000 format is only decoded by HPR 400. EM3000 is the preferred format.

Interface format: RS-422.

9600 bps, 8 data bits, 1 stop bit, no parity.

Any length between each telegram.

Telegram format: The telegram consists of 10 bytes.

Note !

For each of the data groups, LSB first and MSB next.

Byte	Description	Values
1	Status	EM1000 format: 00h. EM3000 format: 90h: valid data, full accuracy. 91h - 99h: valid data, reduced acc. 9Ah - 9Fh: non-valid data, normal operation A0h - AFh: error.
2		90h
3, 4	Roll lsb, msb	+/-179.99 deg. Positive port up. Negative data as 2's complement.
5, 6	Pitch lsb, msb	+/-179.99 deg. Positive bow up. 2's complement.
7, 8	Heave lsb, msb	+/-9.99 m. Positive up. 2's complement.
9, 10	Heading lsb, msb	0 - 359.99 deg.

Example: Roll: 2.0, Pitch: -2.0, Heave: 0.9, Course: 155.1
Telegram: 9090 C800 38FF 5900 963C

Seapath serial line format

Seatex Simrad EM1000 and EM3000 serial line format.

Further details see chapter *Gyro formats MRU serial*.

Synchro

Format: Synchronous 16-bit.

Signal: 11.8/90 Vrms.

Reference: 26/115 Vrms, 400 hz.

Sin Cosin

Not Implemented.

4-20 mA

Compass 4-20 mA current loop.

Format: 4 – 20 mA = 0 - 360 deg.

Sync spare

Connected to SDCM synchro 0 in spare position.

Format: Synchronous 16-bit.

Signal: 11.8/90 Vrms.

Reference: 26/115 Vrms, 400 hz.

3 VRU FORMATS

NMEA serial line format

NMEA serial line format.

Further details see chapter *Gyro formats NMEA serial*.

MRU serial line format

Seatex Simrad EM1000 and EM3000 serial line format.

Further details see chapter *Gyro formats MRU serial*.

Seapath serial line format

Seatex Simrad EM1000 and EM3000 serial line format.

Further details see chapter *Gyro formats MRU serial*.

Piro40 90°

Piro40 - 90.

Type: Analogue sinus vru.

Format: +/-10 V = +/-90 deg.

Piro40 15°

Piro40 - 15.

Type: Analogue sinus vru.

Format: +/-10 V = +/-15 deg.

Sync spare

Connected to SDCM synchro 1 and 2 in spare position.

Format: Synchronous 16-bit.

Signal: 11.8/90 Vrms.

Reference: 26/115 Vrms, 400 hz.

Sperry analogue

Sperry accustar. This vru is mounted in the PMT transducer.

Type: Analogue linear vru.

Format: +/- 10 V = +/-60 deg.

Schaevitz

Schaevitz LSRP - 14.5.

Type: Analogue linear vru.

Format: +/-5 V = +/-14.5 deg.

MRU 20° 10v

Seatex MRU.

Type: Analogue linear vru. Use the MRC programme to program the unit.

Format: +/-10 V = +/-20 deg.

Vru 200A

Honeywell VRU200A.

Type: Analogue linear vru.

Format: +/-15 V = +/-67.5 deg.

Blank page

857-160898

HPR 400 Binary Communication Protocol

This document describes the binary telegrams transmitted from the Operator Station in the Kongsberg Simrad HiPAP/HPR 400 systems. It also describes some of the Ascii sentences transmitted from and received by the Operator Station.

The Ascii sentences complying with the NMEA 0183 rules are described in the Kongsberg Simrad note 160045, "NMEA 0183 Sentences".

Document revisions

Rev	Documentation Department		Hardware/Software design		Project/Product Management	
	Date	Sign	Date	Sign	Date	Sign
A	10.03.98	GM	24.07.98	HJP	03.08.98	JEF
B	15.05.03	GM	16.05.03	THG	16.05.03	JEF
C						
D						

(The original signatures are recorded in the company's logistic database.)

Contents

1	INTRODUCTION.....	5
1.1	Definitions.....	5
2	GENERAL TELEGRAM FORMAT.....	7
2.1	Time of telegram transmission	7
2.2	Floating point data format.....	8
2.3	Serial line format.....	9
2.4	Ethernet format.....	9
2.5	Kongsberg Simrad ADP ethernet header.....	9
3	TELEGRAMS SENT FROM THE OPERATOR STATION	10
3.1	Message 1, Transponder position data	10
	Example	14
3.2	Message 2, LBL position	15
	Time Header.....	18
	Example	18
3.3	Message 4, LBL Ranges	19

Document history

(The information on this page is for internal use)

Rev. A	Original issue. Earlier, the HPR 400 binary protocol document was distributed as an unofficial document, not included in the manuals. The last unofficial document was "Communication Protocol V2.1" - file name SWTS013.H / 94.11.17.
Rev. B	Updated the Message 2, LBL position - Pos_north. Removed sections 3.4 / 3.5 / 3.6 and chapter 4.

1 INTRODUCTION

This note is a technical documentation that may be changed. Please contact Kongsberg Simrad before implementing the reception of telegrams to assure that the note matches the SW version in the actual HiPAP/HPR system to be interfaced.

1.1 Definitions

The following abbreviations are used in this document:

APOS	Acoustic Positioning Operator Station, the “new” Operator Station.
BYTE	8 bit data
HiPAP	High Precision Acoustic Positioning
HPR	Hydroacoustic Positioning Reference system
HSC 400	HPR 400 System Controller, the “old” Operator Station.
LBL	Long Base Line
ms	Milliseconds
REAL	32 bit floating point data
REAL_64	64 bit floating point data
ROV	Remotely Operated Vehicle
SSBL	Super Short Base Line
TD	Transducer
TP	TransPonder
WORD_16	16 bit data

APOS is the new Operator Station with the Windows Man Machine Interface. It replaces the older HSC 400. All telegrams are not yet implemented in the APOS.

HPR 400 and HiPAP are two different types of transceivers. They may both be connected to either an HSC 400 or to an APOS Operator Station. In either case, the telegrams are delivered by the Operator Station, and the format is independent of the physical units involved.

Later in the note, the term **The system** means the HiPAP/HPR 400 system. The term **The Operator Station** is used as a common term for HSC 400 and APOS.

The binary telegrams and the ascii sentences are the transmitted to the Com ports and to the ethernet as specified in the configuration menus in the Operator Station. The same telegram may be configured to be sent to many, to one or to none destinations.

The following “terms” are used:

X - POSITION	Athwart ship distance to transponder, positive direction towards starboard.
Y - POSITION	Fore and Aft ship distance to transponder, positive direction forward.
Z - POSITION	The transponder depth, positive direction downwards.
SLANT RANGE	The distance to the transponder.
COURSE	Vessels heading, 0 - 360 degrees, positive direction turning clockwise.
ROLL	Vessels roll, -180 -, 0, - 180 degrees, positive direction is vessels port side up.
PITCH	Vessels pitch, -180 -, 0, - 180 degrees, positive direction is bow up.

Positive vessel y-axis is forward, positive vessel x axis is towards starboard and positive vessel z-axis is downwards. This is a left-hand coordinate system.

2 GENERAL TELEGRAM FORMAT

The binary telegrams transmitted on asynchronous serial lines follow the same general format with telegram heading and telegram tail. The contents of the data block depends on the message type, as described for each message.

The telegrams transmitted on ethernet have another heading, as described in 2.4 and 2.5.

Index	Content	Size
000	Start character	BYTE
001	Block length N	WORD 16
003	Message type	BYTE
004	Destination	BYTE
005	Data Block with N bytes	
N+5	Sumcheck	WORD 16
N+7	Stop character	BYTE

Start character The start character is 55 hex.

Block length The block length defines the length of the data block.

Message type The message type defines the message transmitted. It is a number between 1 and 255.

Destination The destination defines the device to which this telegram is transferred. It is not in use, and it is always set to 0.

Data block The data block contains the message itself.
The length N depends on the Message type. The data block for the different message types are explained in the next chapters.

Sumcheck The sumcheck is the 16 bit sum of all bytes in the telegram, except the sumcheck itself and the stop character. The sum is calculated by byte+byte addition.

Stop character The stop character is equal to 0AAH.

Note ! *The start character and the stop character are not unique. They may also occur as data within the telegram.*

2.1 Time of telegram transmission

The time delay between the end of one telegram and the start of the next one is at least 30 ms. It separates the telegrams.

2.2 Floating point data format

Both 32 bits and 64 bits floating formats are used in the telegrams. They are coded according to the IEEE standard 754. 32 bits floating numbers use the single precision data format. They are named REAL throughout the note. 64 bits floating numbers use the double precision data format. They are named REAL_64 throughout the note.

The REAL format occupies 4 contiguous bytes of memory, (32 bits).

SIGN	EXPONENT	SIGNIFICANT
31	30	23 22
		0

Sign Sign = 0 if value is positive or zero
Sign = 1 if value is negative.

Exponent The exponent field contains a value offset by 127. The actual exponent can be obtained from the exponent field by subtracting 127. The field is zero if the REAL value is zero.

Significant The byte with the lowest address contains the least significant 8 bits of the significant, and the byte in the highest address contains the sign and the 7 most significant bits of the exponent.

The REAL_64 format occupies 8 contiguous bytes of memory as shown below. The explanation of the fields is similar to the explanation for REAL, except that the exponent is biased with 1023 instead of 127.

SIGN	EXPONENT	SIGNIFICANT
63	62	52 51
		0

2.3 Serial line format

The serial line format is:

Baud rate: Selectable between 300 and 38400 baud.
The default value is 9600 baud.

Parity: none

Data bits: 8

Stop bits: 1

The least significant byte (bit 0-7) is transmitted first in both WORD_16s, REALs and REAL_64s, followed by the more significant bytes.

2.4 Ethernet format

When the telegrams are sent to external units via ethernet, they are sent as an UDP message. They can be sent as individual messages or as broadcast messages.

The telegram contains the "Message type" and the "Data Block" in addition to the UDP blocks.

Index	Content	Size
0	Message type	BYTE
1	Data block with N bytes	

The meaning of the "Message Type" and the "Data Block" is as described in the start of the chapter for the serial lines.

2.5 Kongsberg Simrad ADP ethernet header

The Kongsberg Simrad ADP header consists of 16 bytes. They replace the message type in the normal header explained above. The Kongsberg Simrad ADP header is only used when explicitly requested in the Operator Station menus.

3 TELEGRAMS SENT FROM THE OPERATOR STATION

3.1 Message 1, Transponder position data

The position message telegram contains SSBL transponder position data and sensor data related to the position measurement. It is transmitted each time a new position is calculated.

Block content	Size
Tp_index	WORD_16
Operation_mode	BYTE
Sync_mode	BYTE
Tp_type	BYTE
Tp_operation	BYTE
Pos_data_form	BYTE
Reply_status	BYTE
Filt_X_pos	REAL
Filt_Y_pos	REAL
Filt_Z_pos	REAL
X_pos	REAL
Y_pos	REAL
Z_pos	REAL
Slant_range	REAL
P_course	REAL
P_roll	REAL
P_pitch	REAL
Td_beam	BYTE
Td_type	BYTE
Td_num	WORD_16
Diagnostic	WORD_16
Stand_dev	REAL
Instr_data (*)	REAL

Tp_index defines the Tp for which the position is valid.
It is a number from 1 to 298. The indexes below 100 are for the low frequency Tps (The Axx Tps), the indexes between 100 and 200 are for the medium frequency Tps (The Bxx Tps), and the indexes between 200 and 298 are for the high frequency Tps (The Cxx Tps).

Examples: A02 is coded with Tp_index 2.
B01 --"-- 101.
B56 --"-- 156.

Operation_mode Contains the Operation mode of the transceiver.
00 equals standard navigation mode.
01 " simulated position test mode. (Training)

Sync_mode Contains the synchronization mode of the transceiver.
0 equals No synchronization.
1 " Sequence sync.
2 " Interrogation sync.

Tp_type Defines the transponder type:
000 equals transponder
001 " depth transponder
002 " inclinometer transponder
003 " diff. incl. transponder
004 " compass transponder
005 " acoustic control transponder
006 " beacon
007 " depth beacon
010 " responder drive 1
011 " responder drive 2
012 " responder drive 3
013 " responder drive 4

Tp_operation Defines the operation mode of the transponder:
000 equals fixed standard transponder
001 " mobile -----"-----

Pos_data_form Defines the position coordinate format:
Bit 0 = 0 vessel oriented, cartesian.
Bit 0 = 1 north oriented, cartesian.
Bit 3 = 1 Ping count data valid
The coordinates are normally vessel oriented, that is bit 0 is 0.

Reply_status Defines the transponder reply status. When the whole byte is zero, the reply is ok.

Bit 0 and 1 contains information about timeouts.
Value 1 means timeout on the first pulse, value 2 means timeout on the second pulse and value 3 means timeout on the third pulse.

Bit 2 set Ambiguity error X angle.

Bit 3 set Ambiguity error Y angle.

Bit 4 set Reply rejected by the software filter.

Bit 5 set VRU or gyro error. The position is calculated with zero course and/or zero roll and pitch. The VRU and/or gyro error is reported in the DIAGNOSTIC parameter.

Filt_X_pos The filtered x - position coordinates of the transponder. Transponders horizontal athwart ship distance from reference point. A meter value in REAL format.

Filt_Y_pos The filtered y - position coordinates of the transponder. Transponders horizontal fore and aft ship distance from reference point. A meter value in REAL format.

Filt_Z_pos: (Depth) The filtered z - position coordinates of the transponder. Transponders vertical distance from reference point. A meter value in REAL format.

X_pos The raw x - position coordinates of the transponder. Transponders horizontal athwart ship distance from reference point. A meter value in REAL format.

Y_pos The raw y - position coordinates of the transponder. Transponders horizontal fore and aft ship distance from reference point. A meter value in REAL format.

Z_pos: (Depth) The raw z - position coordinates of the transponder. Transponders vertical distance from reference point. A meter value in REAL format.

Slant_range The direct raw slant range from the vessel's transducer to the transponder. A meter value in REAL format.

P_course The vessels course at the time of transponder position measurement. A value in REAL format, 0 to 360 degrees.

P_roll The vessels roll at the time of transponder position measurement. A value in REAL format, +/-180 degrees.

P_pitch The vessels pitch at the time of transponder position measurement. A value in REAL format, +/-180 degrees.

Td_beam Defines the transducer beam, 0=wide, 1=narrow.

Td_type defines the transducer type.

0	equals	30 kHz	wide beam only
1	"	30 kHz	wide/medium beam
2	"	30 kHz	wide/narrow beam
3	"	30 kHz	PMT-300, wide/wide extended baseline.
4	"	15 kHz	wide/medium
5	"	30 kHz	LBL
6	"	15 kHz	LBL
7	"	30 kHz	SSBL NMT-301
8	"	30 kHz	SSBL tracking td-er
9	"	30 kHz	HiPAP

Td_num defines the transducer number 1 to 4 used in the positioning.

Diagnostic Defines the transceiver hardware status.

Error information	Error index
15	8 7 0

The least significant byte of this WORD_16 parameter contains an index, defining one error. If there are more than one error, the index will alter between the error indexes. The most significant byte of the parameter contains additional information for the error reported by the index.

The error indexes are reserved according to the following plan:

1 to 31	General errors
32 to 63	Application specific errors
64 to 255	Debug diagnostics.

The General errors are:

1	HW reset
2	Fatal transceiver error
3	VRU error
4	Gyro error
5	External serial line error
6	Transmitter error
7	DSP error
8	Tracking td error

When the Operator unit receives an error index, it is displayed together with the additional information. The additional information is displayed as a hex number. The meaning of the numbers is explained in the Operator's manual.

Stand_dev The expected accuracy of the position. It is based on the covariance data calculated for the SSBL position. It is equal to the statistical sum of the major and minor semiaxes of the error ellipse displayed around the position.

Instr_data (*) This is only used if any of the below cases are true:
 If the message contains data from a Inclinometer transponder, (Tp_type = 2 or 3), the first two reals contain the Inclination of the transponder. The first contains X inclination and the second contains the Y inclination.
 If the message contains data from a compass transponder, (Tp_type = 4), the first real in Instr_data contains the heading of the compass transponder.
 If the message contains data from a depth transponder, (Tp_type = 1), the first real in Instr_data contains the depth measured by the transponder.
 If bit 3 in Pos_data_form is set, the first real in Instr_data contains the ping count from the transponder with resolution million ping.
 If Td_type is tracking td, the last real value contains the tracking td angle.

Example

Telegram:

```
55 3a 00 01 00 94 00 01 00 00 00 00 00 fc
e4 c9 42 72 46 6e c2 47 cd 80 40 bb ed c9
42 25 85 6e c2 c2 cc 8c 40 80 5b e8 42 00
00 00 00 00 00 00 00 00 00 00 00 01 01 02
00 00 00 58 5c 00 40 b0 11 aa
```

The data block of the telegram decoded:

TpOmSmTtToPfSt	X	Y	Z
148 1 0 0 0 0 0	100.95	-59.57	4.03
	100.96	-59.63	4.40

Rang	Crs	Roll	Pitc	TbTtT#Diag	Std
116	0.0	0.00	0.00	1 1 2	0 2.01

3.2 Message 2, LBL position

The LBL position telegram contains a position relative to the origin of the Tp array. The position is of the vessel or of another object. The telegram is transmitted each time a new position is calculated. If the Transponder array is north oriented, the coordinates are relative to true North, else they are relative to local north.

Block content	Size
Sequence_number	WORD_16
Time_header (7)	BYTE
Interrogation_age	WORD_16
Tp_array	BYTE
Td_num	BYTE
Pos_east	REAL_64
Pos_north	REAL_64
Depth	REAL
Hor_err_ellipse_direction	REAL
Hor_err_ellipse_major	REAL
Hor_err_ellipse_minor	REAL
Z_standard_deviation	REAL
Pos_type	BYTE
Pos_status	BYTE
P_course	REAL
P_roll	REAL
P_pitch	REAL
Diagnostic	WORD_16

Sequence_number The sequence number is incremented for each LBL interrogation. It is reset each time LBL positioning is started. Range 0 - 65535.

Time_header See subchapter below.

Interrogation_age Time since interrogation of transponder array. The resolution is 1ms.

Tp_array When the LBL position is calculated in Navigation mode, it contains the Tp array number in use (1 and upwards).
When the position is calculated in Training mode, it contains 255.

Td_num Defines the transducer number in use.

1 to 4	means td 1 to 4 on transceiver	1
5 to 8	"	2
9 to 12	"	3
13 to 16	"	4

0 has a special meaning. Then the position is calculated based on measurements on more than one transducer.

Pos_east The East and North coordinate of the position in meters. Positive East value is towards east, and positive North value is towards north.
Pos_north The coordinates are local coordinates.
 The HSC 400 also includes global UTM coordinates.

Depth The depth coordinate in meters. Positive value is downwards. It is the vertical distance from the sea level to the reference point of the object being positioning.

Hor_err_ellipse_direction Each LBL position has an one sigma error ellipse associated with it. The direction is the angle in degrees between the north axis and the major axis of the ellipse.

Hor_err_ellipse_major The major semiaxis of the error ellipse.

Hor_err_ellipse_minor The minor semiaxis of the error ellipse.

Z_standard_deviation The standard deviation of the depth.

Pos_type

0	-	Position of the vessel
1	-	Position of ROV1
:	:	
16	-	Position of ROV16
17	-	Position of TP range Position no 1
:	:	
20	-	Position of TP range Position no 4

Bit 7 is 0 if the coordinates are local. It is set if they are UTM coordinates.

Pos_status This variable tells the status of the position calculation. The statuses with an asterisk in the table below are so serious that no position is contained in the telegram.

- 0 Ok position.
- 1 The measured ranges match badly the calculated position. The range residuals are big.
- 2 The position calculation did converge in the horizontal plane, but not vertically.
- 3 The calculation of the interrogation time in MuLBL mode did not converge.
- 16* Too few ranges are measured.
- 17* The position calculation does not converge.
- 18* Internal HPR computation error.
- 19* No initial position is calculated.

P_course An average of course read at the time of pulse arrival.

P_roll An average of roll read at the time of pulse arrival.

P_pitch An average of pitch read at the time of pulse arrival.

Diagnostic See Message 1, Transponder position data.

Time Header

The format of the Time_header is:

Block content	Size	Index	Resolution	Range
Day	BYTE	0	1 Day	1-31
Month	BYTE	1	1 Month	1-12
Year	BYTE	2	1 Year	0-99
Hours	BYTE	3	1 Hour	0-23
Minutes	BYTE	4	1 Minute	0-59
Seconds	BYTE	5	1 Second	0-59
1/100th seconds	BYTE	6	1/100 second	0-100

It defines the clock when the position is valid.

Example

Telegram:

```
55 41 00 02 00 08 00 18 07 62 0d 2b 23 4a
f8 0a ff 02 7a a5 cf f8 d3 fc 68 40 3d e2
a3 fb 5d 14 59 c0 70 01 9c c0 ef b3 a8 41
ff 3a 07 3e da a1 fc 3d ca 39 18 3e 00 00
00 00 00 00 00 00 00 00 00 00 00 00 00 00
50 17 aa
```

The data block of the telegram decoded:

```
Seqno ddmmyyhhmmss.hh Age Ar Td East
      8 240798134335,74 2808 ff 2 199.90

North Depth Dir Major Minor Dsigm Pt Ps
-100.32 -4.88 21 0.13 0.12 0.15 0 0

Crs Roll Pitch Diag
0.0 0.00 0.00 0
```

3.3 Message 4, LBL Ranges

The LBL_ranges message contains raw measured ranges to the transponders, and VRU and compass data. This Message is transmitted just after the Message 2 (LBL position). The two messages have the same sequence number.

Block content	Size
Sequence_number	WORD_16
Range_age (8)	WORD_16
Tp_array	BYTE
Td_num	BYTE
Operation_mode	BYTE
Sync_mode	BYTE
Pos_type	BYTE
Reply_status (8)	BYTE
Range (8)	REAL
P_course	REAL
P_roll	REAL
P_pitch	REAL
Diagnostic	WORD_16

Range_age, reply_status and range consist of a list with 8 entries, one for each transponder.

Sequence_number The sequence number is incremented for each LBL interrogation. It is reset each time LBL positioning is turned ON. Range 0 - 65535.

Range_age Time since reception of the range. Resolution 1ms.

Tp_array When the LBL position is calculated in Navigation mode, it contains the Tp array number in use (1 and upwards).
When the position is calculated in Training mode, it contains 255.

Td_num Defines the transducer number in use.

1 to 4	means td 1 to 4 on transceiver	1
5 to 8	"	2
9 to 12	"	3
13 to 16	"	4

Operation_mode See Message 1, Transponder position data.

Sync_mode contains the synchronization mode of the transceiver.

0	equals	No synchronization.
1	"	Sequence sync.
2	"	Interrogation sync.

Pos_type 0 - Position of the vessel
 1 - Position of ROV1
 :
 16 - Position of ROV16
 17 - Position of TP range Position no 1
 :
 20 - Position of TP range Position no 4

Reply_status_n Defines the reply status. When bit 0 to 5 are zero, the measurement is OK.

Bit 0 and 1 contains information about timeouts.

Value 1 means timeout on the first pulse, value 2 means timeout on the second pulse and value 3 means timeout on the third pulse.

Bit 2 set Ambiguity error or angle rejected X angle.

Bit 3 set Ambiguity error or angle rejected Y angle.

Bit 4 set Range rejected by the software filter.

Bit 5 set Vru or gyro error. The position is calculated with zero course and/or zero roll and pitch. The VRU and/or gyro error is reported in the DIAGNOSTIC parameter.

Bit 6 and 7 contain information about what is measured. The contents of the two bits are either 00 (no measurement), 80H (only the range is measured) or C0H (both the range and the directions are measured).

Bit 7 set The range is measured OK.

Bit 6 set The SSBL directions are measured OK.

Range_n The measured range to the transponders.

P_course An average of course read at the time of pulse arrival.

P_roll An average of roll read at the time of pulse arrival.

P_pitch An average of pitch read at the time of pulse arrival.

Diagnostic See Message 1, Transponder position data.

108368 / AA067

HPR 300 telegrams

This document describes the HPR 300 external equipment telegram formats.

Document revisions

Rev	Date	Written by	Checked by	Approved by
A	23.04.91	NB	JB	RB
B	27.01.99	GM	RB	KE
C				
D				

Contents

1	TRANSPONDER TELEGRAMS.....	7
1.1	Summary	7
1.2	Introduction	8
1.3	Format of telegrams sent from the HPR system	9
1.3.1	Telegram contents	9
1.3.2	HEAD (1 byte).....	10
1.3.3	ROLL, or inclinometer TP X-angle (2 bytes).....	10
1.3.4	PITCH, or inclinometer TP Y-angle (2 bytes).....	11
1.3.5	COURSE (2 bytes).....	11
1.3.6	TRANSPONDER INDEX (1 byte)	11
1.3.7	X-POS RANGE (3 bytes), Y-POS OR BEARING (3 bytes), Z-POS DEPTH (3 bytes)	11
1.3.8	STATUS (1 byte)	13
1.3.9	TIMEOUT (1 byte).....	13
1.3.10	TRANSPONDERS IN SEQUENCE (3 bytes)	14
1.3.11	TRACKING TD-ANGLE (2 bytes)	14
1.3.12	TEST (1 byte)	15
1.3.13	TRANSPONDER TYPE (1 byte)	15
1.3.14	TRANSPONDER SPECIFICATION (1 byte).....	16
1.3.15	TRANSDUCER (1 byte)	17
1.3.16	TD STATUS (1 byte).....	18
1.3.17	STANDARD DEVIATION SIGMA (1 byte).....	18
1.3.18	CHECKSUM (1 byte)	18
1.3.19	END OF TELEGRAM (1 byte)	18
1.4	Format of telegrams received by the HPR system	19
1.4.1	Telegram contents	19
1.4.2	HEAD (1 byte).....	19
1.4.3	TRANSPONDER INDEX (1 byte)	20
1.4.4	TRANSPONDER TYPE (1 byte)	20
1.4.5	TRANSPONDER SPECIFICATION (1 byte).....	20
1.4.6	TRANSDUCER (1 byte)	21

1.4.7	COORDINATE ORIENTATION AND REFERENCE POINT (1 byte)	21
1.4.8	SYMBOL 1 (6 bytes)	22
1.4.9	SYMBOL 2 (6 bytes)	22
1.4.10	VECTOR 1 (4 bytes)	22
1.4.11	SYMBOL MODE (1 byte)	23
1.4.12	SPARE (1 byte)	23
1.4.13	CHECKSUM (1 byte)	23
1.4.14	END OF TELEGRAM (1 byte)	23
1.5	Time of telegram transmission	23
2	2'S COMPLIMENT BINARY CODING	25
2.1	Introduction	25
2.2	Telegram reception	25
2.3	Position data in cartesian coordinates	26
2.3.1	General	26
2.4	Positioning data in polar coordinates	30
2.4.1	General	30
2.4.2	Course	30
2.4.3	Roll and Pitch	30
3	PRACTICAL POINTS	33
4	HARDWARE INTERFACE CONNECTIONS	34

Document history

Rev. A First issue.

Rev. B Updated to new document standard.

Blank page

1 TRANSPONDER TELEGRAMS

1.1 Summary

Kongsberg Simrad's Hydroacoustic Position Reference (HPR) system is often used by other equipment to determine the position of the vessel relative to an underwater structure on the seabed or a remotely operated vehicle (ROV).

Normally the HPR system and the external equipment exchange the necessary information using "telegrams". Each telegram consists of a number of bytes sent over a serial communications link (20 mA current loop or RS232C).

Normally, the HPR system sends a telegram to the external equipment with new position information as soon as new data is available. The telegrams contain the following information as standard:

- The position of a transponder.
- The transponders entered into the system by either external equipment or the operator.
- The transducer and beam width being used.
- Other control information.

209 systems delivered in 1981 or earlier, which do not have this telegram format, may be updated if convenient.

1.2 Introduction

The telegrams between the HPR system and external equipment are transmitted using asynchronous drivers and receivers.

Each byte has a 7-bit code, 1 parity bit (odd parity), 1 start bit and 2 stop bits. The format of the bytes is shown in *Figure 1*.

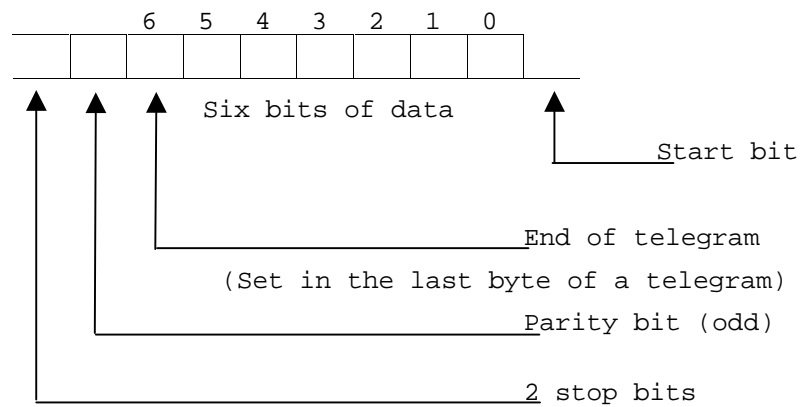

Figure 1 The format of the telegram bytes

1.3 Format of telegrams sent from the HPR system

1.3.1 Telegram contents

Telegrams sent from the HPR system consist of the following bytes:

Byte contents	No. of bytes	Byte index <u>in telegram</u>
HEAD	1 byte	0
ROLL (or X-angle)	2 bytes	1
PITCH (or Y-angle)	2 bytes	3
COURSE	2 bytes	5
TRANSPONDER INDEX	1 byte	7
X-POS OR RANGE	3 bytes	8
Y-POS OR BEARING	3 bytes	11
Z-POS OR DEPTH	3 bytes	14
STATUS	1 byte	17
TIMEOUT	1 byte	18
TP's IN SEQUENCE	3 bytes	19
TRACKING TD ANGLE	2 bytes	22
TEST	1 byte	24
TP TYPE	1 byte	25
TP SPECIFICATION	1 byte	26
TRANSDUCERS	1 byte	27
TD STATUS	1 byte	28
KALMAN FILTER WINDOW	1 byte	29
CHECKSUM	1 byte	30
END OF TELEGRAM	<u>1 byte</u>	31
	32 bytes	

The rest of this chapter contains a description of the bytes.

1.3.2 HEAD (1 byte)

The HEAD byte defines the mode in which the HPR system is running, and some parameters concerning the coordinates used in the telegrams.

Bit 0 is set when running in normal acoustic mode (run mode).

Bit 1 is set when running in test mode.

Bit 2 is set if the position is calculated in polar coordinates. It is zero if the position is calculated in cartesian coordinates.

Bit 3 is set if north is the Y direction in cartesian coordinates and the zero bearing direction in polar coordinates (north oriented coordinates). It is zero if the heading of the vessel is the Y-direction in cartesian coordinates and the zero-bearing direction in polar coordinates (vessel oriented coordinates).

Bit 4 is set if the coordinates contained in the telegrams are filtered by a Kalman filter. It is zero if the coordinates are unfiltered. This has to be agreed between the customer and Simrad.

Bit 5 is set if the position reference point is the spare (e.g. the bow) reference point of the vessel. It is zero if the reference point is the main (e.g. the moonpool) reference point of the vessel.

If the telegram does not contain any position information, bits 2, 3, 4 and 5 are invalid.

Bits 0, 1 and 5 may be changed by the operator using the control unit. The other bits may not be altered.

1.3.3 ROLL, or inclinometer TP X-angle (2 bytes)

These bytes normally contain the roll angle read from the Vertical Reference Unit.

When the telegram contains transponder/responder position information, the angle is read when the reply is received. Otherwise it will be read immediately before the telegram transmission.

The first byte contains the 6 MSBs of the angle, and the last byte contains the 6 LSBs. The angle is coded in 2's complement.

The resolution (weight of the LSB) is .0878906 degrees (equal to 360 degrees divided by 2^{12}) and the angle is consequently in the range $+180^\circ$ to -180° . A positive roll angle means that the vessel's starboard side is down.

If the telegram contains information about an inclinometer TP, these bytes contain the X-angle of the TP (marked 1 on the top of the TP). The format is the same as for the roll angle. A positive X-angle means that the TP is leaning towards starboard.

1.3.4 PITCH, or inclinometer TP Y-angle (2 bytes)

These bytes contain the pitch angle read from the vertical reference unit.

It is read just after the roll angle, and they have the same format.

A positive pitch angle means that the bow of the ship is up.

If the telegram contains information about an inclinometer TP, these bytes contain the Y-angle of the TP (marked 2 on the top of the TP). The format is the same as for the pitch angle. A positive Y-angle means that the TP is leaning forwards.

1.3.5 COURSE (2 bytes)

These bytes contain the angle read from the Gyro Compass.

It is read just after the roll angle, and they have the same format.

Normally, the course angle is the angle between the north vector and the Y-direction. Seen from above, clockwise is the positive angle direction.

1.3.6 TRANSPONDER INDEX (1 byte)

If the telegram contains transponder position information, this byte contains the number of that transponder (from 1 to 16).

Otherwise this byte is zero.

The transponders 1 to 9 have indices 1-9. The transponders □, ⊙, ∇, X,Y, emergency-A and emergency-B, have indices 10 to 16 (decimal).

1.3.7 X-POS RANGE (3 bytes), Y-POS OR BEARING (3 bytes), Z-POS DEPTH (3 bytes)

These bytes contain the position of the transponder/responder. The position is either in cartesian coordinates X, Y and Z or in polar coordinates; range, bearing and depth (indicated in bit 3, Head byte).

The Y direction is alongships forward when vessel-oriented, and north when north-oriented.

The X direction is atwartships starboard when vessel-oriented, and east when north-oriented.

The Z direction is downward, i.e. depth.

The range is the horizontal distance to the transponder/responder measured on the sea surface.

The bearing angle is the angle between the Y direction (along-ships forward or north) and the range vector. Positive angle is clockwise seen from above.

The format of the X, range, Y and Z bytes are shown in the figure below.

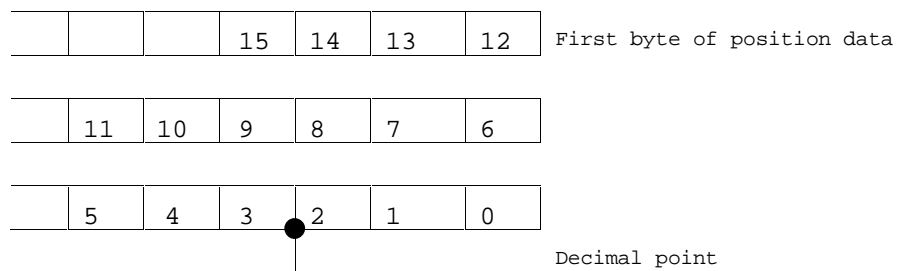

The position is coded in 2's complement. The resolution (weight of the LSB) is 0.125 m, and the position is consequently in the range ± 4096 m.

The format of the bearing angle is the same as for the roll angle. When polar coordinates are used, there is a spare byte between the 2 bearing bytes and the depth bytes.

1.3.8 STATUS (1 byte)

This byte contains some the HPR system status information.

The format of the byte is shown below:

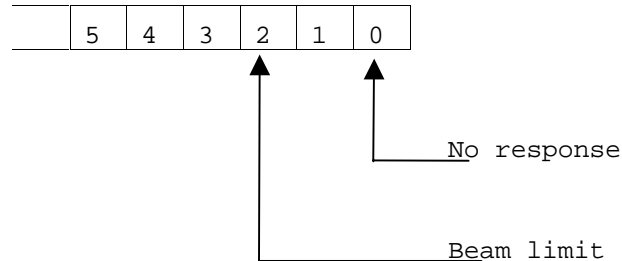

The "no response" bit is set when:

- No position reply within the timeout limit.
- The reply is rejected by the programs.
- There is an interrogator failure.

When "No Response" is received, the TRANSPONDER CODE byte tells the system which transponder/responder the HPR system failed to receive a correct reply from. The position bytes do not contain any position information.

The BEAM LIMIT bit is set when the reply is received in the outer part of the beam in operation. It is only valid for a fixed transducer without the tracking-medium or tracking-narrow facilities.

1.3.9 TIMEOUT (1 byte)

A TP may reply with one or more pulses.

Bit 0 in timeout is set if the first pulse is not received.

Bit 1 is set if the second pulse is not received.

Bit 2 is set if the third pulse is not received.

1.3.10 TRANSPONDERS IN SEQUENCE (3 bytes)

These 3 bytes define the total number of transponders operating in the system introduced by either the operator or the external equipment.

The format of the bytes is shown below. The bits associated with transponders activated in the system at the present, are set.

Byte 1

5	4	3	2	1	0
		B	A	Y	X

Byte 2

5	4	3	2	1	0
∇	⊙	□	9	8	7

Byte 3

5	4	3	2	1	0
6	5	4	3	2	1

The TP numbers and symbols are drawn inside their associated bits.

1.3.11 TRACKING TD-ANGLE (2 bytes)

These 2 bytes contain the angle of the tracking transducer when a reply from the transponder is received.

The first byte contains the 6 MSBs of the angle, and the last byte contains the 6 LSBs.

The format of the angle is as for the roll angle.

1.3.12 TEST (1 byte)

This byte contains information about the self diagnostics performed by the transceiver unit.

Bit 0 is set when a data memory (RAM) error is detected.

Bit 1 is set when a program memory (PROM) error is detected.

Bit 2 is set when an error in one of the other cards in the interrogator is detected. (FIC-TRAN, SDC-TRAN, TSB-TRAN, TRC-TRAN, RPC-TRAN, IOC-TRAN, FIL-TRAN, TRANSDUCER).

Bit 3 is set when an error in one of the serial lines connected to the transceiver is detected. (INTF-DP, INTF-DSPL, INTF-TRAN, INTF-STB, INTF-PORT, STB-MOTOR, PORT-MOTOR).

Bit 4 is set when the processor is restarted. (UMC-TRANC).

1.3.13 TRANSPONDER TYPE (1 byte)

This byte contains a binary number indicating what transponder type the telegram contains data from.

- 0 means standard TP
- 1 " responder
- 2 " depth TP
- 3 " beacon
- 4 " depth beacon
- 5 " inclinometer TP

1.3.14 TRANSPONDER SPECIFICATION (1 byte)

This byte contains some parameters of the transponders of the telegram.

Bit 0 is set if the TP is mobile (e.g. mounted on a ROV), and zero if it is fixed. This information is entered by the operator and may be used by the DP system to decide which TPs should be used as DP reference.

Bit 1 is set if the TP is a low interrogation rate TP. It is zero if it is a normal interrogation rate TP.

Bit 2 is set if the TP is a low priority TP. It is zero if it is a normal priority TP.

Bit 3 is set if the operator has specified a fixed depth for the TP. The fixed depth information is used by the programs to compensate for ray bending.

1.3.15 TRANSDUCER (1 byte)

This byte contains information about the transducer and the beam width.

The format is as shown below:

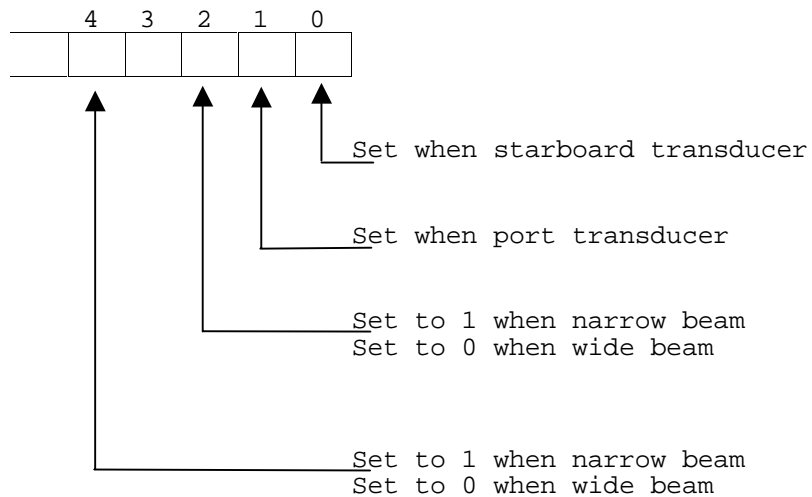

Bit 2 defines the beam selected by the operator for the TP.

Bit 4 identifies the beam used by the HPR system in the last interrogation. When the operator selects narrow beam, the HPR system has to use wide beam to establish TP position before switching to narrow beam. When the operator selects wide beam, the HPR system uses wide beam.

When the telegram contains position information of the Z transponder/responder, the byte defines the status when the reply was received. Otherwise they define the status when the telegram was built up.

The term "narrow beam" in this code is rather imprecise. It means the narrow beam of the actual TD, (i.e. not the wide beam).

The "narrow beam" may be either the medium beam (± 30 degrees) of the standard TD, the narrow beam (± 15 degrees) of the fixed TD or one of the narrow beams of the tracking TD.

1.3.16 TD STATUS (1 byte)

This byte defines the status of the transducers connected to the HPR system.

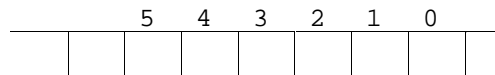

Bits 5, 4 and 3 are for the port transducer, while bits 2, 1 and 0 are for the starboard transducer.

For the 2 LSBs (0 & 1, and 3 & 4)

- 00 = auto track
- 01 = stopped
- 10 = train manual left
- 11 = train manual right

For the MSBs (2 and 5)

- 0 = fixed transducer
- 1 = tracking transducer

1.3.17 STANDARD DEVIATION SIGMA (1 byte)

Standard deviation is calculated within the software filter, based on 4 measurements. When "timeout" and "Ping accepted" Sigma will increase up to a value of 13,5% of predicted range.

1.3.18 CHECKSUM (1 byte)

This byte contains the exclusive-or of all bytes of the telegram, not including the checksum byte itself and the end of telegram byte.

1.3.19 END OF TELEGRAM (1 byte)

This byte contains 40H, and defines the end of the telegram.

It is the only byte of the telegram with bit 6 set.

1.4 Format of telegrams received by the HPR system

1.4.1 Telegram contents

The telegrams sent from external equipment to the HPR system consist of the following bytes:

Byte contents	No. of bytes	Byte index in telegram
HEAD	1 byte	0
TRANSPONDER INDEX	1 byte	1
TRANSPONDER TYPE	1 byte	2
TP SPECIFICATION	1 byte	3
TRANSDUCER	1 byte	4
COORDINATE ORIENTATION AND REFERENCE POINT	1 byte	5
SPARE	1 byte	6
SYMBOL 1	6 bytes	7
SYMBOL 2	6 bytes	13
VECTOR 1	4 bytes	19
SYMBOL MODE	1 byte	23
SPARE	1 byte	24
CHECKSUM	1 byte	25
END OF TELEGRAM	<u>1 byte</u>	26
	32 bytes	

1.4.2 HEAD (1 byte)

The HEAD byte specifies whether the HPR system must change the mode in which it is running, and if the rest of the telegram is valid or not.

Bit 0 set means that the whole telegram is valid. If this is zero, only the head byte will be handled by the HPR system.

Bit 2 set means change to test mode.

Bit 3 set means change to run mode.

1.4.3 TRANSPONDER INDEX (1 byte)

This byte specifies a transponder to be either inserted into or removed from the transponder sequence.

The format of the byte is the same as for the transponder index byte sent from the HPR system.

Examples:

- Transponder index byte equal to zero means no change in the transponder sequence.
- Transponder index byte equal to 05 means that transponder 5 shall be either inserted into or removed from the transponder sequence. If transponder 05 is already in the transponder sequence, it will be removed. Otherwise it will be inserted.

As may be seen from the examples, a transponder index other than 00 specifies a change in the transponder sequence.

1.4.4 TRANSPONDER TYPE (1 byte)

This byte defines the type of transponder being inserted into the transponder sequence by this telegram.

- 0 means standard TP
- 1 " responder
- 2 " depth TP
- 3 " beacon
- 4 " depth beacon
- 5 " inclinometer TP

1.4.5 TRANSPONDER SPECIFICATION (1 byte)

This byte defines some parameters of the transponder being inserted into the transponder sequence by this telegram.

Bit 0 is set if the TP is mobile, and is zero if it is fixed.

Bit 1 is set if the TP is a low interrogation rate TP, and is zero if it is a normal interrogation rate TP.

Bit 2 is set if the TP is a low priority TP.

1.4.6 TRANSDUCER (1 byte)

This byte specifies the transducer and beam width to be used for the TP in the transponder index byte.

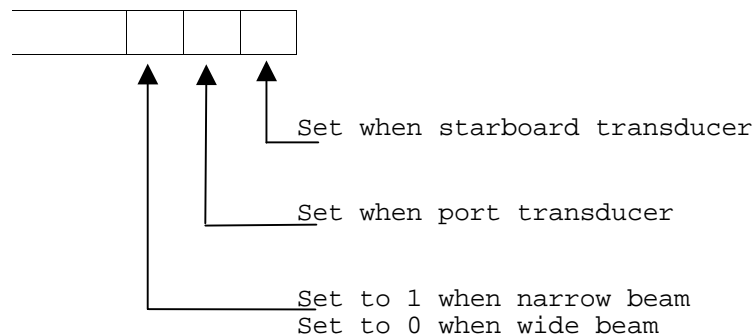

The HPR system will start to interrogate the TP on the selected transducer in wide beam.

If the HPR system receives valid replies from the TP in wide beam, and the external equipment has specified narrow beam, the HPR system will switch to narrow beam. It will then continue to interrogate in narrow beam. If the system receives too many timeouts or too great a variance in the measurement, it will switch back to wide beam.

It will use wide beam until the TP position is re-established, then it will switch to narrow beam. All this will be done automatically by the HPR system.

1.4.7 COORDINATE ORIENTATION AND REFERENCE POINT (1 byte)

This byte defines the orientation of the coordinates and their reference point used in telegrams sent from the HPR system.

Bit 0 set means that the information in bit 4 is valid.

Bit 1 set means that the information in bit 5 is valid.

Otherwise this information is as specified by the operator.

Bit 4 set means that the coordinate system will be north oriented. Otherwise it will be vessel oriented. The orientation selected by the operator will always be used on the HPR system display.

Bit 5 set means that the spare reference point is to be used as the reference point of the coordinates. Otherwise the main reference point of the vessel will be used. Bit 5 will effect both the data in the telegrams sent from the HPR system, and the data on the HPR system display.

1.4.8 SYMBOL 1 (6 bytes)

The external equipment may specify up to 2 custom defined symbols and 1 vector to be displayed at the HPR system display. The symbol mode byte, which will be explained later, defines which of these 3 symbols/vectors are to be displayed, and if they shall blink or not.

The form of the 2 symbols must be discussed with Kongsberg Simrad.

The first 3 bytes of symbol 1 define the X-coordinate of the first symbol. The last 3 bytes of symbol 1 define the Y-coordinate of the first symbol.

The format of the X and Y values are the same as for the X, Y and Z position data in the telegrams sent from the HPR system.

The X and Y values are vessel-oriented, with the vessel in the origin.

1.4.9 SYMBOL 2 (6 bytes)

These 6 bytes define the X and Y coordinates of the second custom symbol. The format is the same as for symbol 1.

1.4.10 VECTOR 1 (4 bytes)

These 4 bytes define the direction of the custom specified vector.

The first 2 bytes contain the sine value of the angle between the Y direction and the vector, and the 2 last bytes contain the cosine value of the same angle.

Seen from above, clockwise is the positive angle direction.

The format of the angle is described in the figure.

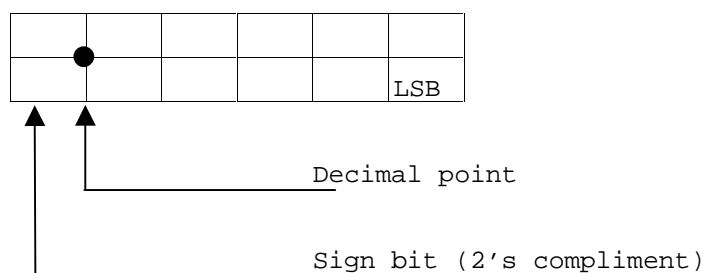

1.4.11 SYMBOL MODE (1 byte)

The format of this byte is explained in the figure below.

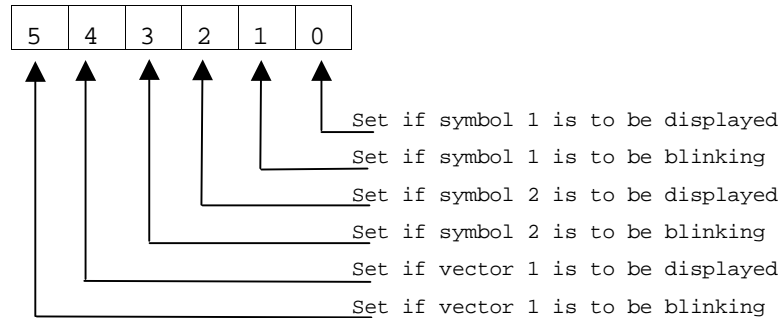

When the bits 0, 2 or 4 are zero, the corresponding symbol or vector (if it is displayed) will be removed from the display.

1.4.12 SPARE (1 byte)

Not used in the standard systems.

1.4.13 CHECKSUM (1 byte)

This byte only contains the exclusive-or of all the bytes of the telegram, not including the checksum byte itself and the end-of-telegram byte.

1.4.14 END OF TELEGRAM (1 byte)

This byte is equal to 40H, and defines the end of the telegram.

1.5 Time of telegram transmission

The external equipment or the operator determines the number of transponders to be in the system. The HPR system does however determine the sequence of transponder activations, and when to activate them.

The transponders are activated in the sequence □, ⊙, ∇, X, Y, 1, 2, 3, 4, 5, 6, 7, 8, 9, emergency A and emergency B. (Assuming they are active in the system at the time).

The interval between the activation of the same transponder is constant if possible under the physical circumstances. If that is not possible, they are activated with as little delay as possible.

The telegrams with position information are sent to the external equipment immediately after the position is calculated.

When no transponder is in the system, dummy telegrams are sent with fixed intervals (6.2 secs.). That is done to allow the external equipment to test that the HPR system is alive. These dummy telegrams do not contain any transponder codes, and consequently no position information. The rest of the dummy telegrams, however, are valid.

The interval between the end of one telegram and the start of the next is a minimum of 150 ms. This may be changed if required by the customer.

As explained in chapter 1, each byte consists of 7 data bits, 1 parity bit, 1 start bit and 2 stop bits, i.e. a total of 11 bits.

The transmission time of one byte is consequently $11/\text{baud rate}$ seconds.

Example:

The transmission time T of a telegram from the 209/200 and 309/300 transceiver with a baud-rate of 2400 baud, is:

$$T = 32 \times 11 / 2400 \text{ s} = 0,147 \text{ s} = 147 \text{ ms}$$

This may easily be seen on an oscilloscope.

The computing time of a TP reply in the HPR system transceiver is approximately 300 ms. The computing of a TP reply is done while the next TP in the sequence is being interrogated. When the travel time of the interrogation and the reply pulse in water is less than 300 ms (corresponds to slant range 225 m), the HPR system may interrogate 3 TPs each second. That matches with a 150 ms interval between stop and start of telegrams and a baud-rate of 2400 baud.

If a longer interval or a slower baud-rate is selected, the telegram transmission will become a bottleneck in the system. Then TP interrogations have to wait for telegram transmissions to be finished. Simrad therefore recommends 2400 baud and an interval between stop and start of telegrams of less than or equal to 150 ms.

2 2'S COMPLIMENT BINARY CODING

2.1 Introduction

This part is a guide to deciphering the 2's complement coded information contained in the HPR system telegrams. It is designed for those programmers unfamiliar with binary number manipulation.

Three logic operators are used: AND, OR and EX-OR, which might be unfamiliar to some. No attempt is made to explain what these operators do in logic terms, the reader is simply instructed when to use them. In these examples, it is assumed at all times that each byte of data is contained in a 16 bit register. However, this might not necessarily be so. This will depend on the computing system in use.

2.2 Telegram reception

The initial problem in dealing with the HPR system telegrams is that of receiving one full telegram in the same order that it was transmitted. The usual method of accomplishing this is to use the "End of Telegram" byte as a reference to mark the end of a telegram. (This is the only byte which has bit 6 set, and this corresponds to 64 decimal or 40 in hexadecimal). Thus, a method of telegram reception could be as follows:

The receiving computer should store bytes until it receives 64 decimal, which corresponds to the end of a telegram. It may now process the bytes of the telegram just received.

- The first step in this processing should be to check that the number of bytes in the telegram are correct and that the EX-OR of all bytes in the telegram is 64 decimal.

The next byte that the computer receives (after 64 decimal) is the first byte of the next telegram. The interval between these two bytes can vary from 0.15 secs to 4 secs. There is no interval between bytes belonging to the same telegram.

Figure 2 illustrates the above.

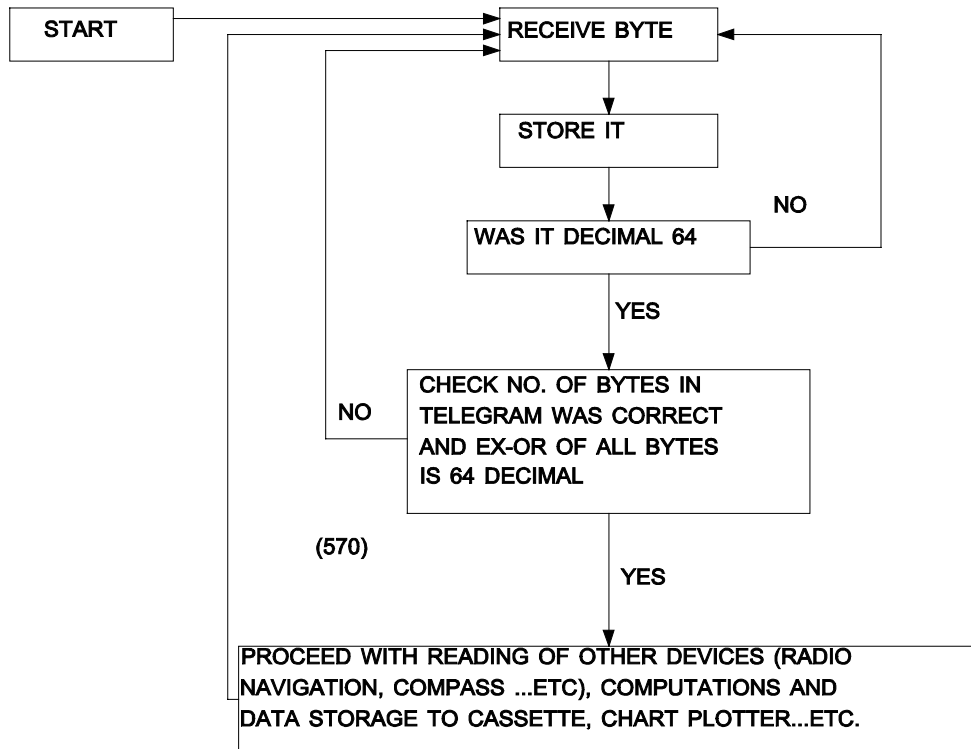

Figure 2 Telegram reception flow diagram

2.3 Position data in cartesian coordinates

2.3.1 General

The three coordinates, X, Y and Z, are each given as 3 bytes. These 3 bytes need to be assembled to make one 16-bit number, before decoding the 2's complement. The following is a method for accomplishing this:

1. Of the three bytes, the first contains 4 bits and the second and third each contain 6 bits of relevant data.

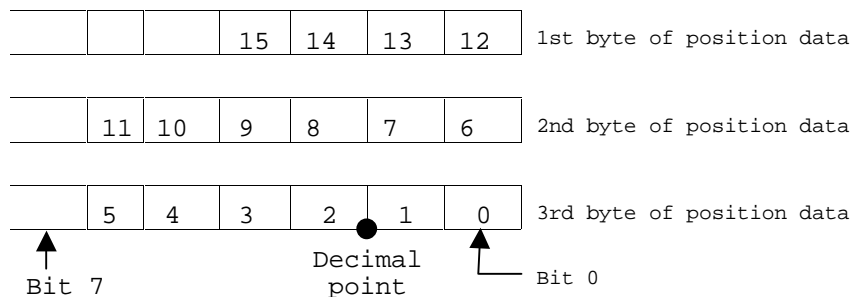

Note !

Only the lower 8 bits of the 16-bit register are shown.

Take the first byte and "AND" it with decimal 15 (00001111 binary). This clears bits 4 to 15. Shift the result twelve places to the left. Take the second byte, and "AND" it with 63 decimal (00111111 binary). This clears bits 6 to 15. Shift the result six places to the left. Take the third byte, and "AND" it with decimal 63 (00111111 binary). Leave this result as it is. The data is now in the following positions:

3 X 16-BIT REGISTERS

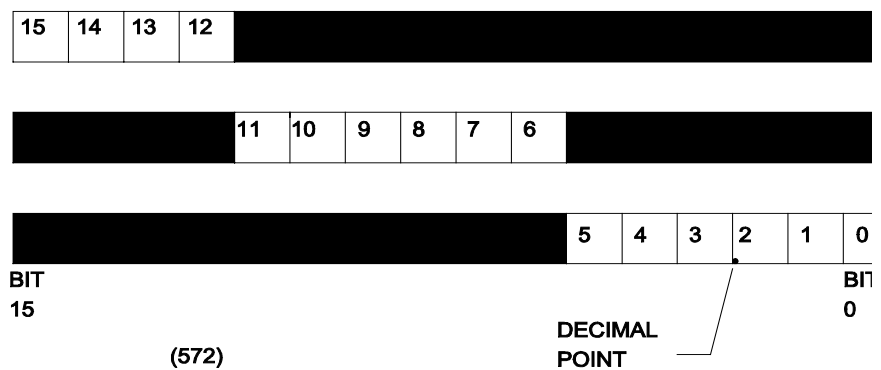

The shaded areas contain only zeros.

The first and second bytes should now be "OR'd", and the result "OR'd" with the third byte. The coordinate will now be a 16-bit binary number, held in 2's complement form.

2. Check the most significant bit (MSB) (i.e. bit 15).

If bit 15 is zero, convert the binary to a decimal number and divide the result by 8 to place the decimal point in the correct position. This is a positive number.

If bit 15 is a one, complement the complete number and add 1 to it. Convert the binary number to a decimal, and divide it by eight to place the decimal point in the correct position. This number should then be multiplied by -1 to make it negative.

The above procedure should be used for all three coordinates (X, Y & Z).

Example 1:

The 3 bytes for the X coordinate are:

```

0 0 0 0 1 1 1 1   byte 1
0 0 1 1 0 0 1 1   byte 2
0 0 0 0 1 0 1 1   byte 3
    
```

Bits 0 to 3 of byte 1 contain relevant information. Bits 0 to 5 of bytes 2 and 3 also contain relevant information.

"AND-ing" byte 1 with decimal 15 masks out bits 4 to 15, and "AND-ing" bytes 2 and 3 with decimal 63 masks out bits 6 and 7 in each byte. After shifting byte 1 twelve places to the left and byte 2 six places to the left, the situation is as shown below:

```

1 1 1 1 0 0 0 0 0 0 0 0 0 0 0 0   byte 1
0 0 0 0 1 1 0 0 1 1 0 0 0 0 0 0   byte 2
0 0 0 0 0 0 0 0 0 0 0 0 0 1 0 1 1   byte 3
↑                               ↑
bit 15                          bit 0
    
```

"OR" the numbers to give:

```

1 1 1 1 1 1 0 0 1 1 0 0 1 0 1 1
↑                               ↑
bit 15                          bit 0
    
```

Refer to note on page 32 .

Bit 15 is a 1, therefore the number is negative. Take the complement of the number and add one. This gives:

0 0 0 0 0 0 1 1 0 0 1 1 0 1 0 1 = 821 decimal

Divide this by 8 to place the decimal point correctly, and multiply by -1 to make it negative.

$$X = \frac{821}{8} \times (-1) = -102.63 \text{ metres}$$

Example 2:

The 3 bytes for the Y coordinate are:

0 0 0 0 0 0 0 0 byte 1

0 0 0 0 1 1 0 1 byte 2

0 0 1 0 1 1 1 0 byte 3

After the "AND" and "OR" operations, this gives:

0 0 0 0 0 0 1 1 0 1 1 0 1 1 1 0 = 878 decimal

↑

↑

bit 15

bit 0

Refer to note on page 32 .

Bit 15 is zero, so the number is positive and no complementing is required. Divide by 8 to put the decimal point in the correct position.

$$Y = \frac{878}{8} = 109.75 \text{ metres}$$

2.4 Positioning data in polar coordinates

2.4.1 General

The range and depth are deciphered in the same manner as shown for the X, Y and Z coordinates.

The bearing is deciphered in a slightly different manner. Byte 3 of the 3 bearing bytes is a spare and can be ignored.

"AND" the first byte with decimal 63 and shift it six places to the left. "AND" the second byte with decimal 63 and "OR" it with the first byte. The result is a 12 bit number. To convert this to an angle between 0° and 360°, convert the binary number to decimal and multiply by 0.0878906. This gives an angle in the required range.

$$0.0878906 = \frac{360^\circ}{4096} \text{ (in a circle)}$$

4096 (max. decimal number with 12 bits)

That is: 0.0878906 is the weight of the LSB (least significant bit).

2.4.2 Course

The course can be decoded by the same method used to decode the bearing given with the position in polar coordinates.

2.4.3 Roll and Pitch

Convert the 2 bytes to a 12 bit number as shown for the bearing in polar coordinates.

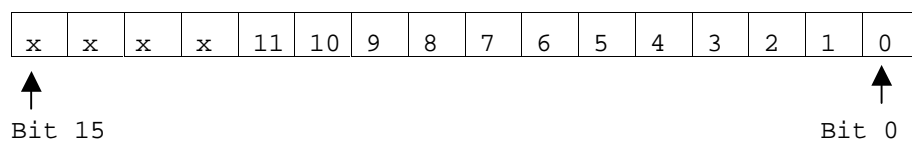

Positions marked with an X will be zero.

It is usual to convert roll and pitch to an angle between -180° and +180°.

This is achieved as follows:

If bit 11 is a zero, convert the binary number to a decimal and multiply it by 0.0878906.

If bit 11 is a one, complement all 12 bits and add one to the resulting number. Convert the binary number to decimal, and multiply by -0.0878906 to make the number negative and to place decimal point correctly.

A negative ROLL corresponds to Starboard side up.

A negative PITCH corresponds to Stern up.

Example 3:

For position data given in polar coordinates, the bearing bytes are as follows:

0 0 1 0 0 1 0 0 byte 1

0 0 0 1 1 0 1 0 byte 2

0 0 0 0 0 0 0 0 byte 3

Byte 3 will always be zero so this can be ignored. Bits 0 to 5 of bytes 1 and 2 contain the relevant information, so "AND" both bytes with decimal 63. Byte 1 must be shifted 6 places to the left. This gives:

0 0 0 0 1 0 0 1 0 0 0 0 0 0 0 0 byte 1

0 0 0 0 0 0 0 0 0 0 0 0 1 1 0 1 0 byte 2

"OR" the two numbers to give:

0 0 0 0 1 0 0 1 0 0 0 1 1 0 1 0 = 2330 decimal

Refer to note on page 32 .

As the bearing angle is required in the range 0° to 360°, there is no need to worry about the 2's complement. Multiply the number by 0.0878906 to obtain the angle.

$$2330 \times 0.0878906 = 205^\circ$$

Example 4:

The two Roll bytes received are the same as given in Example 3 for bearing. After "AND-ing" and "OR-ing", this gives:

0 0 0 0 1 0 0 1 0 0 0 1 1 0 1 0

↑

Bit 11

As the pitch and roll angles are required in the range -180° to $+180^{\circ}$, bit 11 must be checked and the 2's complement taken into account. Bit 11 is set (negative angle) so complement the number and add 1. This gives:

0 0 0 0 0 1 1 0 1 1 1 0 0 1 1 0 = 1766 decimal

Multiply by -0.0878906 to make number negative and to place the decimal point correctly.

$$\text{Roll} = 1766 \times -0.0878906 = -155^{\circ} \text{ (i.e. starboard side up)}$$

Example 5:

The two pitch bytes received are:

0 0 0 1 0 1 0 0 byte 1

0 0 0 1 1 0 1 0 byte 2

After "AND-ing" and "OR-ing", this gives:

0 0 0 0 0 1 0 1 0 0 0 1 1 0 1 0 = 1306 decimal

↑

↑

bit 11

bit 0

Bit 11 is zero so there is no need to complement. Multiply by 0.0878906 to obtain the pitch.

$$\text{Pitch} = 1306 \times 0.0878906 = 114.8^{\circ} \text{ (i.e. bow up)}$$

Note !

OR, EX-OR or ADD may be used here. Although these are by no means the same operation, they will each give the same result when used in this case.

3 PRACTICAL POINTS

When using the HPR system in conjunction with a radio navigation system to accurately plot the position of an underwater object, it is important that both systems give data for a similar moment in time. Occasionally a reply might not be received from a transponder upon interrogation (as might happen during vessel manoeuvring). When this happens, the telegram transmitted for that interrogation will not contain "valid" position data, and this can be detected by examining bit 0 of the status byte of the telegram. Equally important is the fact that if the radio navigation system is read first and the computing system is waiting for a "valid" telegram from the HPR system (i.e. one which contains position data) a time delay occurs between the reading of the radio navigation and the HPR systems. Thus the following points should be kept in mind to help reduce errors due to software:

1. Check the status byte for validity of position data.
2. Check that no significant time delay can occur between the reading of the HPR system and any other system which requires to be time referenced with the HPR system.

4 HARDWARE INTERFACE CONNECTIONS

The telegrams described in this note are sent from the HPR system transceiver on two current loop interfaces and two RS232C interfaces.

The baud-rate of these four interfaces may be 110, 300, 600, 1200, 2400 or 4800 bauds. The four interfaces have the same baud-rate.

Telegrams to the HPR system transceiver from external equipment are sent to the HPR system using either a current loop interface or an RS232C interface.

For information regarding the interfaces refer to the *HPR 400 standard Installation manual*.

Transponder Quick Reference Guide

Refer to the respective transponder Instruction manual for more detailed information about the individual transponder.

Safety information

Due to safety rules, the "Safety information for transponder and transponder battery" must be read before handling transponders or separate transponder batteries.

Refer to the respective transponder instruction manual / the Transponder Safety Data Sheet (859-164733 / In-ternet)

Battery

As a standard, a SPT / MPT transponder contains a lithium battery.

Hazards identification

Short-circuits, overheating, mechanical damage and exposure to water can start chemical reactions and high currents inside the transponder lithium battery. This can generate noxious gases and / or danger of explosions.

- **Noxious gases** - thionyl chloride, sulphur dioxide, hydrogen chloride and chlorine. All personnel that have been exposed to the noxious gases should immediately be seen by a doctor.
- **Explosion** - if the transponder explodes, either the transducer or the bottom end cap will blow out, or the transponder becomes fragmented. This can cause serious damages on personnel / equipment.

Handling

All personnel that handle transponders must know the transponder's status:

'Functioning' – 'Failing' – 'Unknown'

A transponder with unknown status, must be handled as a transponder that is failing. A 'failing' transponder must be handled as possible water ingress.

- All transponders recovered from the sea, should be placed in a safe place out on deck and controlled for **minimum 2 hours**:
- Look for outer damages that could involve a water leakage.
- The transponder housing temperature must be checked to verify a possible temperature increase in the battery.

Transponders in general

General

The SPT / MPT transponders are compatible with the Kongsberg Simrad HiPAP / HPR systems. The Kongsberg Simrad SPT / MPT transponders includes units deep water rated to 1000 / 3000 / 6000 meters.

The transponders are supplied with different transducer heads, according to the transponder specifications. The transponder name indicates the transponder specification.

A transponders are designed for operation in water only!

Transponder name

The transponder name consists of:

- Model name (three letters)
- Model number (three digits)
- Any options included (letters after digits)

Model name

SPT: SSBL Positioning Transponder
MPT: Multifunction Positioning Transponder

Model number

The three digit describes:

- Digit 1: frequency band
- Digit 2: depth rating and
- Digit 3: beamwidth

Options

Available options are described in the respective Instruction manual.

Handling a heated or self-heated transponder / transponder battery

Cool down the battery with copious amounts of cold water:

- Immerse the transponder / separate transponder battery in the sea for 12 hours or permanent.
- If this method is impossible, the transponder / separate battery can be cooled down by use of a fire hose.

Use necessary protection equipment.

Wash out chemical reaction products with water.

Opening a transponder

- Open the transponder in a safe place out on deck, shielded from people and vital equipment.
- Use necessary protection equipment.
- Do not stand in front of transducer or bottom end cap, when opening a transponder.

Storage

- A transponder that is failing, must be stored in a safe place out on deck, shielded from people and vital equipment.

- A transponder that is functioning, and separate batteries can be stored indoors. A fire station, with fire hose (water), must be placed outside the storeroom.

Disposal

- For safe disposal, contact a company that has been approved to collect and dispose lithium batteries.

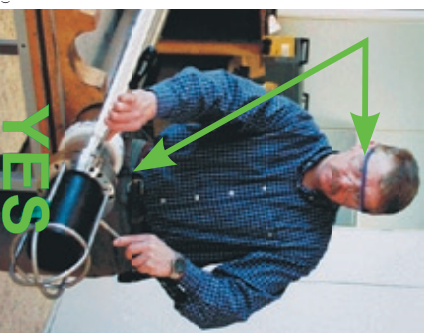

Refer to the respective instruction manual for special tools and procedures required to open a transponder.

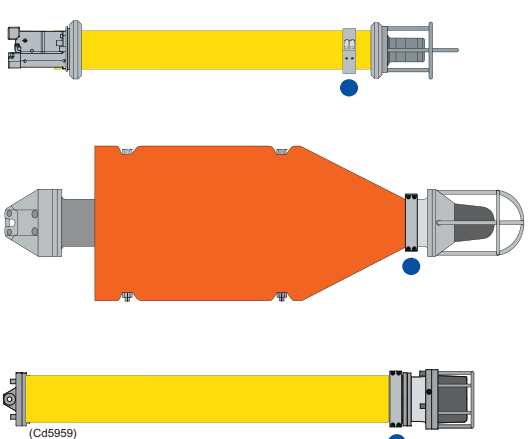

Identification

The identification clamp ring is tightened around the transponder body. This ring is engraved with:

- Transponder name
- Registration number (unique serial number)
- Frequency channel.
- Type of battery

If the transponder configuration and battery is changed, the channel numbers (A) and the type of battery (B) can be altered by setting pegs into different holes in the clamp.

The figure below shows an identification clamp ring for a transponder using channel B57 and includes a lithium battery. Name and serial number is engraved on the other side.

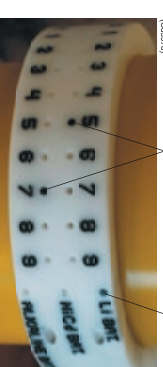

Transponder Quick Reference Guide

Refer to the respective transponder Instruction manual for detailed information about the individual transponder.

● Connecting the battery

At delivery, the transponder battery is disconnected, and must therefore be connected before transponder deployment.

To connect the battery, the unit must be opened. This is described in detail in the respective manual.

NBI: It is important to follow these procedures ●.

- 1 Grab the connector firmly using both hands.
- 2 Press the connector onto the battery plug.
- 3 When you connect the battery, listen for the transponder initialization:
 - Three bursts should be transmitted at a rate of one per second.
 - If you do not hear any bursts, disconnect the battery immediately, and wait minimum 20 sec. before you connect it again.
- 4 When the battery correctly connected, assemble the transponder:
 - **NBI** remember to inspect the O-rings and backup rings (if used). Refer to the respective instruction manual.



Set-up of the system

All transponders are preset by the manufacturer. The channel setting may be changed if required. This can be done as follows:

- Use of internal switches, or
- with use of acoustic telemetry from a HIPAP / HPR 400 system. The HPR 300 systems can not send telemetry for this purpose.

References

For information about set-up of a transponder, refer to APOS Instruction manual / On-line help.

Pre-deployment checks

- 1 Perform a visual inspection of the transponder.
- 2 Perform a functional check before deployment to ensure it will operate correctly once it has been positioned on the seabed.
- 3 The transponder tester the TTC 400 can be used for functional check.

Deployment

At deployment, the unit must be positioned with the transducer upright. Ensure a clear line of sight between the transponder's head and the ship's transducer. The release mechanism (if fitted) must be attached to the shackle.

The shackle will ensure the transponder is released smoothly when requested by the operator.

When you deploy the transponder, the anchor-weight must be lifted separately from the transponder.

DO NOT attempt to lift both the transponder and the anchor-weight via the transponder - the transducer cage is only certified for lifting the transponder and the buoyancy collar.

During deployment, prevent the transponder from slamming against other solid objects.

Ready for operation

Once deployed, the transponder is ready for operation. The sensors in your application will respond to requests from the HIPAP / HPR system, when they are enabled using telemetry.

Operation

The operation of the transponder performed at the HIPAP / HPR topside Operator Station. For information regarding operation, refer to APOS Instruction manual / On-line help system.

Recovery checks

After recovery, wash the unit thoroughly in fresh water to dissolve any salt deposits and clean off any sand or silt. If available, an high pressure hose may be used. If the unit is not to be re-deployed in the near future, disconnect the battery.

Refer to safety information on the opposite page.

Mounting

- A transponder may be:
 - Secured to a subsea structure, using mounting brackets.
 - Located on the open seabed. This requires an anchor-weight and a buoyancy collar to hold the transponder securely in position on the seabed.

Changing the battery

To change the battery, the transponder unit must be opened.

If the transponder is fitted with a release unit, disconnect the release plug at the bottom of the battery before removing the battery.

Unplugging the connector from the battery by:

- 1 Support the connector with your left hand and use a screw driver to press the release knob, as you pull out the connector.
- 2 Remove the four nuts and locking washer holding the battery to the chassis.
- 3 Replace the battery pack in the reverse order. How to connect the battery see ●.

- For the SPT 339- / 331- / 139 RspSx transponders read the details for battery connection in the instruction manual.

Maintenance

No maintenance is normally required, apart from washing the unit. To change the battery pack, the unit must be dismantled.

Transport

At transportation and storage, the transducer face and the O-ring grooves must be protected (if the transponder is open).

- All transponders and separate transponder batteries must be shipped in accordance with prevailing regulations.
- During transport the battery must always be disconnected from the electronics.
- Original transponder / battery cages must be used.

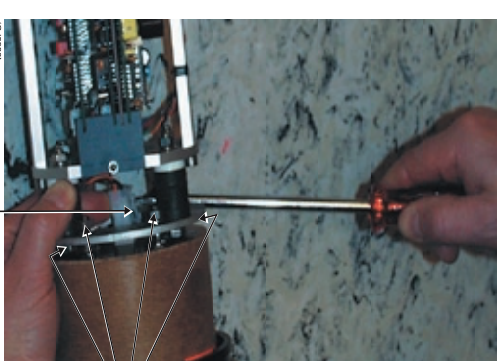

Connector release knob

4 nuts and locking washers

Acoustic Positioning Operator Station (APOS)
for the HPR 400 series / Instruction manual

Acoustic Positioning Operator Station (APOS)
for the HPR 400 series / Instruction manual

Acoustic Positioning Operator Station (APOS)
for the HPR 400 series / Instruction manual

Acoustic Positioning Operator Station (APOS)
for the HPR 400 series / Instruction manual

Acoustic Positioning Operator Station (APOS)
for the HPR 400 series / Instruction manual

